

Bauhaus-Universität Weimar

Graduiertenkolleg 1462

Coupled Numerical and Experimental Models in Structural Engineering

**GRK International Workshop 2017
26th - 28th April, Weimar, Germany**

PROCEEDINGS

Local Organization:

Prof. F. Werner
Prof. G. Morgenthal
Prof. T. Lahmer
Prof. M. Kraus
Prof. K. Smarsly
Dr.-Ing. L. Abrahamczyk
Dr. rer. nat. D. Legatiuk

Scientific Committee:

Prof. C. Könke, Weimar, Germany
Prof. K. Gürlebeck, Weimar, Germany
Prof. A. Osburg, Weimar, Germany
Prof. K. Beucke, Weimar, Germany
Prof. G. Meschke, Bochum, Germany
Prof. T. Schanz, Bochum, Germany
Prof. em. D. Hartmann, Bochum, Germany
Prof. Ch. Bucher, Vienna, Austria
Prof. L. Dunai, Budapest, Hungary
Prof. M. Beer, Hannover, Germany
Prof. G. Lombaert, Leuven, Belgium
Dr.-Ing. J. Hildebrand, Ilmenau, Germany
Dr.-Ing. J. Schwarz, Weimar, Germany

Weimar, 2017

Preface

The proceedings at hand are the result from the GRK International Workshop held at the Bauhaus-Universität Weimar, 2017. It comprises a collection of abstracts and articles devoted to the overall topic of the DFG funded research training group 1462: “Coupled Numerical and Experimental Models in Structural Engineering”.

The solution of any engineering problem is based on models. The quality of their results strongly depends on characteristics of the used model. Moreover, modern problems of engineering typically require not only single models, but rather a combination of different partial models. Thus, the coupling quality also has to be taken into account, when assessing model quality.

The research area of the GRK 1462 covers such topics as stochastic, adaptive, inverse and meta-modelling, considering model properties like uncertainty, complexity, robustness and sensitivity.

The authors are both, well experienced specialists and young researchers, from various countries, who share an interest in the description, assessment and evaluation of model quality.

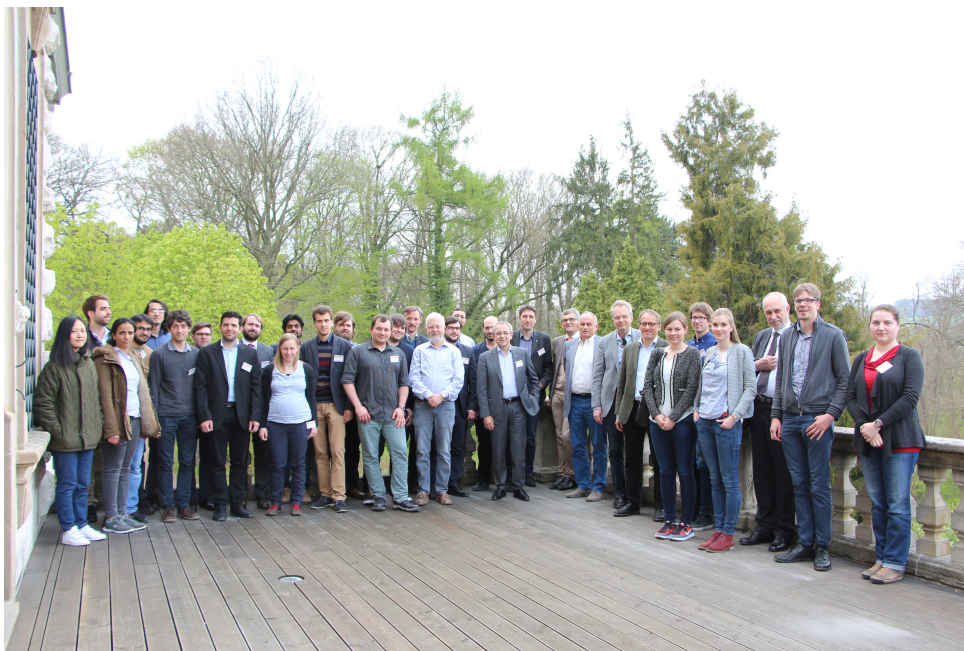

Contents

Preface	1
List of participants	5
Abstracts and papers of participants	8
<i>Climate models — challenges, techniques & quality</i> Georg Feulner	9
<i>Models – turning physical reality into design practice</i> Frank Werner	10
<i>Interaction modeling in mechanized tunneling</i> Günther Meschke	33
<i>Efficient reliability analysis of systems in uncertain environments</i> Michael Beer	34
<i>Recent advances in thunderstorm downbursts: field measurements, weather survey, laboratory tests, numerical simulations and loading of structures</i> Giovanni Solari	35
<i>Evaluation of spatial soil variability in the Pearl River Estuary using CPTU data</i> Emanuel Bombasaro	45
<i>Evaluation of steel buildings by means of non-destructive testing methods</i> Christian Fox, Markus Doktor, Wolfgang Kurz	47
<i>Higher order Riesz-transform in the context of multi-resolution orientation estimation</i> Martin Reinhardt, Swanhild Bernstein, Bettina Heise	48

<i>Optimal experimental design for parameter identification in a geotechnical application</i>	
Raoul Hölter, Elham Mahmoudi, Markus König, Tom Schanz	49
<i>GRK 1462 - Reference project “Poles”: monitoring system, lab experiments and long-term measurements</i>	
Lars Abrahamczyk, Feras Alkam, Hisham Al Hanoun, Luise Göbel, Zouhour Jaouadi, Matthias Kraus, Igor Kavrakov, Dmitrii Legatiuk, Felix Mucha, Sebastian Rau	50
<i>GRK 1462 - Reference object “Telecommunication Tower”: Structural monitoring for model validation</i>	
Volkmar Zabel, Simon Marwitz, Kosmas Dragos, Maria Steiner, Sharmistha Chowdhury, Ina Reichert, Tajammal Abbas	51
<i>Embedding models into wireless sensor nodes for decentralized structural health monitoring</i>	
Kosmas Dragos, Kay Smarsly	52
<i>Model-based force identification and response estimation in structural dynamics</i>	
Geert Lombaert, Kristof Maes	53
<i>Elastic properties of polymer-modified concrete derived from experimental and computational multiscale approaches</i>	
Luise Göbel, Andrea Osburg	54
<i>Multiscale models: from nano-scale to large-scale structures</i>	
Amin Tanhadoust	55
<i>Conceptual modelling methodology for assessment of coupling of models</i>	
Dmitrii Legatiuk	57
<i>Aerodynamic modelling via categorical approach</i>	
Igor Kavrakov, Dmitrii Legatiuk, Klaus Gürlebeck, Guido Morgenthal . . .	58
<i>Inverse and ill-posed problems in coupled systems</i>	
Tom Lahmer, Long Nguyen-Tuan, Muiyiwa Alalade, Bac Nam Vuc	60
<i>Surrogate models for real-time predictions in mechanized tunneling</i>	
Steffen Freitag, Ba Trung Cao, Günther Meschke	61

GRK International Workshop 2017
Coupled Numerical and Experimental Models in Structural Engineering

<i>Investigation of a global adaptive sampling method based on Least-square support vector regression</i>	
Maria Steiner, Tom Lahmer, Jean-Marc Bourinet	63
<i>Cross-evaluation of two measures for the assessment of estimated state-space systems in operational modal analysis</i>	
Simon Marwitz	72
<i>Implementing spectral element method to analyze in-plane vibration of curved beams</i>	
Nima Azizi, M. M. Saadatpour, M. Mahzoon	73
<i>Natural frequency analysis of cracked plates using Singular Finite Element Method</i>	
Parham Memarzadeh, Shiva Fesharakifard	79
Publications in the series of the Research Training Group 1462	88
Appendix A: General information of the workshop	98

List of participants

1. Abrahamczyk, Lars, Bauhaus-Universität Weimar
2. Alalade, Muyiwa, Bauhaus-Universität Weimar
3. Al Hanoun, Hisham, Bauhaus-Universität Weimar
4. Alkam, Feras, Bauhaus-Universität Weimar
5. Beer, Michael, Leibniz Universität Hannover
6. Bock, Sebastian, Bauhaus-Universität Weimar
7. Bombasaro, Emanuel, Bedeschi Handling S.P.A.
8. Bucher, Christian, TU Wien
9. Doktor, Markus, TU Kaiserslautern
10. Dragos, Kosmas, Bauhaus-Universität Weimar
11. Dunai, László, Budapest University of Technology and Economics
12. Feulner, Georg, Potsdam-Institut für Klimafolgenforschung
13. Freitag, Steffen, Ruhr Universität Bochum
14. Fox, Christian, TU Kaiserslautern
15. Göbel, Luise, Bauhaus-Universität Weimar
16. Gürlebeck, Klaus, Bauhaus-Universität Weimar
17. Hausbrandt, Susanne, SGHG Ingenieurgruppe Bautechnik
18. Häußler-Combe, Ulrich, TU Dresden
19. Hölter, Raoul, Ruhr Universität Bochum
20. Hosseini, H.R., Isfahan University of Technology

21. Jafarian, Navid, Isfahan University of Technology
22. Jaouadi, Zouhour, Bauhaus-Universität Weimar
23. Karcher, Christian, TU Ilmenau
24. Kavrakov, Igor, Bauhaus-Universität Weimar
25. Keitel, Holger, SGHG Ingenieurgruppe Bautechnik
26. Könke, Carsten, Bauhaus-Universität Weimar
27. Kraus, Matthias, Bauhaus-Universität Weimar
28. Lahmer, Tom, Bauhaus-Universität Weimar
29. Legatiuk, Anastasiia, Bauhaus-Universität Weimar
30. Legatiuk, Dmitrii, Bauhaus-Universität Weimar
31. Lombaert, Geert, KU Leuven
32. Marwitz, Simon, Bauhaus-Universität Weimar
33. Meschke, Günther, Ruhr Universität Bochum
34. Most, Thomas, Dynardo GmbH
35. Motra, Hem, CAU Kiel
36. Mucha, Felix, Bauhaus-Universität Weimar
37. Nöthlich, Anne-Marie, Bauhaus-Universität Weimar
38. Petryna, Yuri, TU Berlin
39. Rau, Sebastian, Bauhaus-Universität Weimar
40. Reichert, Ina, Bauhaus-Universität Weimar
41. Reinhardt, Martin, TU Freiberg
42. Sahlmen, Jörg, Ruhr Universität Bochum
43. Saubke, Vanessa, Ruhr Universität Bochum
44. Schmidt, Albrecht, Bauhaus-Universität Weimar
45. Schumacher, Jörg, TU Ilmenau
46. Schwarz, Jochen, Bauhaus-Universität Weimar

47. Smarsly, Kay, Bauhaus-Universität Weimar
48. Solari, Giovanni, University of Genova
49. Speitkamp, Winfried, Bauhaus-Universität Weimar
50. Steeb, Holger, Universität Stuttgart
51. Steiner, Maria, Bauhaus-Universität Weimar
52. Tahir, Arslan, Bundesanstalt für Wasserbau
53. Tan, Fengjie, Bauhaus-Universität Weimar
54. Tanhadoust, Amin, Isfahan University of Technology
55. Tuan-Nguyen, Long, Bauhaus-Universität Weimar
56. Werner, Frank, Bauhaus-Universität Weimar
57. Wolf, Frank, Ingenieurbüro Dr. Wolf
58. Wudtke, Idna, Bauhaus-Universität Weimar
59. Zabel, Volkmar, Bauhaus-Universität Weimar

Abstracts and papers of participants

Climate models — challenges, techniques & quality

Georg Feulner¹

1: *Potsdam-Institut für Klimafolgenforschung e.V., Erdsystemanalyse, feulner@pik-potsdam.de*

Abstract. In light of modern climate change, numerical models of the climate have become important tools to understand Earth's complex climate system and to provide projections of future warming. In my presentation, I will outline the challenges involved in building numerical models for individual components of the climate system like the atmosphere or the ocean as well as techniques for model coupling. Finally I will emphasise the importance of a variety of methods to ensure model quality and give examples for the performance of the latest generation of climate models.

Models – turning physical reality into design practice

Frank Werner¹

1: Bauhaus-Universität Weimar, Department of Steel Structures, frank.werner@uni-weimar.de

Abstract. Models form the foundation of any purposeful engineering work. One of the key question in this context is whether Engineers are always able to assess the informational value of the model outputs. Today models achieve new levels of quality. Complex methods of mechanic analysis and powerful computers allow the modelling and graphic representation of almost unlimited models. In the engineering sciences the prognosis of functional capability, safety, and reliability of structures is based on partial models. However, the trust in the predictive capability of a particular engineering model today remains largely based on the experience of the engineer. Evaluations of model quality require a scale, in the form of a norm or a standard. Such norms depend on the quality of the data and must have an objective capacity. In other words, Quality is evaluated Quantity. The estimation of quality for global models is closely linked to the specific requirements which result from the use of the expected data. As expected, a general method for the evaluation of engineering models could not be established. Standardized values of reliability levels or constructive rules (e.g. in the ECs) require in many cases comprehensive scientific processing.

1 Reality and cognition

Models form the foundation of any purposeful engineering work. They create virtual realities which make the design of desired products (solutions) possible. Based on these, a production process can subsequently be planned. Modern engineering work can draw on a broad theoretical foundation, powerful computing capability, and uses increasingly complex models. It manages large amounts of data and produces expressive colourful graphical representations.

The question arises whether Engineers are always able to assess the informational value of the model outputs. Respectively, which questions must be answered to be able to evaluate the quality of a creative process, consisting of virtual planning and concrete product realisation.

Evolution gradually led to the development of a human super computer, allowing people to experience, and increasingly interpret the world. Human beings are even able to question phenomena and describe them in such a way that these become predictable, or so that creations with and around nature can be planned. This process relies on the ability to create models. The path from creating primitive tools to determining the date of the big bang was long and littered with failure.

The creation of models that make natural phenomena accessible or explicable is rooted in a desire to explain how the world is experienced (see Fig. 1). These **experiences** must match the models predictions. Da Vinci, universal genius and forefather of modern engineering, has expressed this succinctly: Practice is the touchstone of truth!

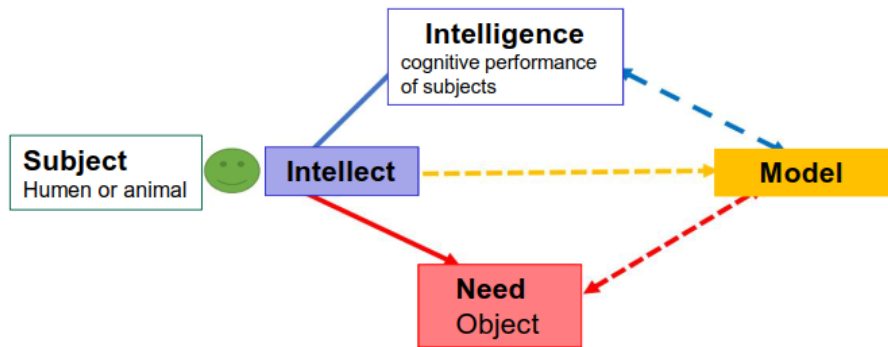

Reality → Model

Every recognition starts from the mind - L.da Vinci

Figure 1: Subject and Model — Every recognition starts from the sense – Da Vinci

It was a long journey from primitive models without theoretical background that could only be experienced through a physical representation (see Fig. 2) to virtual theoretical models today. Some famous historical figures, such as Heron of Alexandria, Archimedes, Vitruv et al., have bequeathed their insights in the form of descriptions or drawings.

A master in this field was Da Vinci, who created an enormous number of often highly detailed model drawings (see Fig. 2). The development of the natural sciences, particularly mathematics, provided the foundation for theoretical models, the virtual representation of a product.

Of particular interest for engineers is the depiction by Galilei for the derivation of bending theory (see Fig. 3). The key issues are obscured in a splendid depiction of a wooden beam which is fixed into a wall. Even a layman can see that this triggers the curiosity of engineers. Modern depictions of this problem are usually significantly simplified (see Fig. 4).

Galilei was not able to validate his hypotheses. There was no (measurement) technology available to him to validate the model in reality. This is a problem modern civil engineering has largely overcome. Not all practical checks are scientifically valid, however. Though, it was not until the nineteenth century when Navier mastered a correct presentation of bending theory, Galilei's image represents the outset for the emergence of theoretical models.

In practice, it is questionable how purposeful it is to equate a theory with a model,



Figure 2: Flying apparatus, source: https://de.wikipedia.org/wiki/Leonardo_da_Vinci



Figure 3: Model of a beam under bending — Galilei, source: http://www.statik-lernen.de/gif/geschichte/galileo_balken.gif

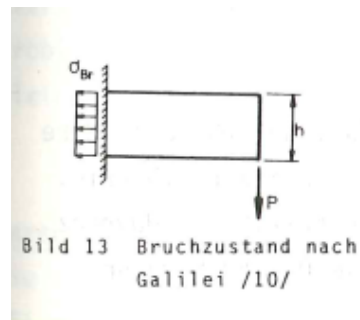

Figure 4: Source: [1], p. 29

i.e. a problem focused representation of reality. It seems more purposeful to consider a model a description of a system, which has input parameters relating to the problem that is to be solved, and which has the purpose of determining system responses.

There is a vast amount of philosophical literature covering this field in much detail and with great intellectual ambition¹. In the field of the engineering sciences the modelling

¹als gedankliches Konstrukt:

challenges are more concrete. In the construction sciences models have long fulfilled the desire to provide problem specific instructions. They must describe reality as closely as possible, and allow for the prediction of events with a degree of certainty. In this context a new consideration has been introduced: safety. This contributes to a conflicting tension in the field of construction engineering between efficiency and reliability.

Master builders (i.e. today's construction engineers, rather than architects) always struggled to create economic, yet safe and reliable products. The number of influences and impacts that must be observed, which at times carry great uncertainties, is vast (see Fig. 10) and parsimony is not a new attitude of modern times.

The engineers' affinity to a comprehensive and extensive sets of standards, which should ideally cover all potential perils of life, is rooted in the history of small and great catastrophes. Add to this a rigorous legislation, as was the case in ancient Babylon, and it takes significant courage and competence (i.e. knowledge and experience about reliable models to dare tackling construction jobs (see Table 1). At times, it may have been recklessness or despair instead.

§229 Law	If a builder build a house for someone, and does not construct it properly, and the house which he built fall in and kill its owner, then that builder shall be put to death.
§230 Law	If it kill the son of the owner the son of that builder shall be put to death.
§231 Law	If it kill a slave of the owner, then he shall pay slave for slave to the owner of the house.

Table 1: Codex — Hammurapi to the liability of Master Builders, source:
<http://www.koeblergerhard.de/Fontes/CodexHammurapi.de.htm>

Today models achieve new levels of quality. Complex methods of mechanic analysis and powerful computers allow the modelling and graphic representation of almost unlimited models - at least so believe an increasing number of trainee engineers. The excessive juggling of models composed of a large number of individual parts, which can become elusive, requires systematization as well as mechanisms which provide adequate end user control.

The desire to research the quality of models is probably rooted in the rampant growth of a collection of models for everyday use. Particularly for all those involved in the development of codes (e.g. Euro Code). The sequencing of models of varying quality (it will be discussed that defining model quality is challenging) demands a discussion of this topic area.

-
- Modell, ein beschränktes Abbild der Wirklichkeit, insbesondere auch eine Repräsentation im Rahmen der logischen Modelltheorie als physische Darstellung
 - Modell (Architektur), eine maßstäbliche Darstellung eines Entwurfes
 - Modell (Ingenieurwissenschaft), eine Nachbildung eines technischen Erzeugnisses in verkleinertem Maßstab

Another material driver to research the qualities of models relates to the increasing analysis of stochastic properties of the systems under consideration. The transition from deterministic concepts to more or less probabilistic concepts (pioneering descriptions in 1926 – see [2]) requires new design methods and tools. Design models based on fixed input data, such as the concept permissible stress, were user friendly. The attempt to make the more complex stochastic models more user friendly, so far has not been very successful in the civil engineering practice. Positive experiences with the use of theoretically demanding models have to be generalised, so these can be used in practice.

This leads back to the fundamental question of model design. Aristoteles already stated²: "It is the mark of an educated man to look for precision in each class of things just so far as the nature of the subject admits".

The (civil) engineering practice requires methods that enable an assessment of models for an effective creation of reliable and cost effective projections and products.

2 Expectations and demands

It is the remit of engineering sciences to provide theoretical foundations for the engineering practice. Key problem areas in this context are the prognosis of products and production processes and the forecast and analysis of natural processes, such as floods. Theoretical tools must aspire to provide a predictable degree of reliability.

Construction constitutes a highly complex interaction of society with the natural environment. Structures are desired to be usable and practicable for a long period of time, often longer than a human life. The demands for reliability, and safety in particular, are significantly greater than in other technological fields. This demands special considerations, and is therefore distinctly different from other technical products, such as cars or computers.

Looking at the distinct qualities of buildings for instance, the following unique factors can be noted, they:

- tend to be unique designs, or at least the boundary conditions such as the construction site is unique;
- have large dimensions;
- are subject to natural and technical effects with stochastic properties over long periods of time;
- exhibit stochastic building material properties and are subject to changes of the construction material and the building properties in a specific interaction with the actions;
- exhibit an interaction of various influences, e.g. ground, material, structure, use, climate with interactions that cannot be precisely defined;

²Aristoteles: *Nikomachische Ethik*, erstes Buch, erstes Kapitel, 5. Absatz, Richard Kraut: "Aristotle's Ethics" in der *Stanford Encyclopedia of Philosophy*

- carry a high level of risk in relation to loss of life and economic loss;
- can cause a high level of destruction of natural resources;
- tend to provide little opportunity for industrialised production at the location of the construction site;
- allow a great freedom of the implementing workers to implement details different than the plans;
- exhibit a high degree of complexity and time pressure during design and build;
- are usually subject to strong economic competition.

Despite the ability to generalise model properties, this particular set of characteristics requires a problem-specific approach.

It is important to emphasize the stochastic properties of the influencing factors (mainly climate phenomena and technical forces), as well as resistance side (mainly material). This issue opens up a research area which intrigues more and more scientists since the beginning of the 20th century [2]. The translation of research findings, e.g. into codes, does not always delight practitioners. Sometimes, "science based design rules" can have bizarre traits [3].

In the engineering sciences the prognosis of functional capability, safety, and reliability of structures is based on partial models. This is gained by means of various abstraction processes, based on the observation and analysis of the behaviour of the structure. Mechanical model representations are developed into mathematical models in the form of boundary value problem and initial value problem. These can be described, for in-stance, through systems of partially coupled differential equations (see Fig. 5).

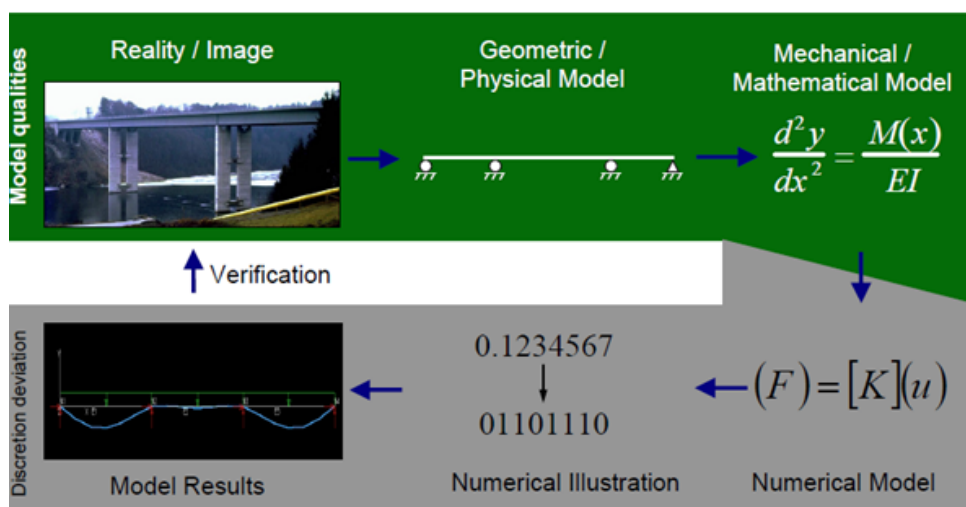

Figure 5: Modelling as a process of abstraction and idealisation

This results in an analysis model, respectively an analytic model, i.e. an explicit model. For different design and planning processes and purposes, appropriate couplings of partial models can be created, e.g. so called simulation models. This term often represents a simplified form of what was formerly known as calculation or analysis. A comprehensive review can be found in Fig. 10.

The basis of all insights about the real world are physical observations of a specific bounded part of reality as researched (experienced) topic (object): By means of measurements of differing quality, input and output variables (data) are captured and analysed. The systematic description of the object's characteristic data can lead to a physical model. It is assumed that the investigated object physically exists.

In principle, two approaches can be distinguished:

- Experiment - AOI (Artificial Object Investigation): definition and creation of an artificial object, which represents the desired properties of a real world object in such a way that these can be measured. These measurements should provide data, which can be analysed in such a way that it allows making statements with regard to particular qualities (\implies Design of experiment).
- Boundary conditions of the real world can/must be adapted, usually by simplifying, to be able to find and describe correlations between input and output data. The quality of results from these experiments does not always lead to insights which are suitable for predictions in the real world.
- Often only part-problems are considered, such as material parameters, which are required in more complex models.
- Experiment - ROI (Real Object Investigation): collection of data from an existing object, can be undertaken over a longer time period (e.g. monitoring), or short term data collection of current state.
- The goals are essentially the same as for AOI.

The quality of data collection and analysis determines the degree of objectivity and hence (un-)certainty of the results.

The differentiation into aleatory and epistemic uncertainties allows a focused approach to adversities of nature (see Fig. 6). Attention of the involved parties - engineers, developers, authorities, etc. – can turn to key problem areas. It also becomes evident, that there are a lot of vulnerabilities in the context of creating "safe" structures. The introduction of algorithmic uncertainties is relatively new. It is a product of the rapid development of computer-based analysis and synthesis methods. It may be open to discussion, whether these fall into the category of epistemic uncertainties.

In former times, when theoretical methods were not yet available, empirical models were derived from experiments. The interpreted results were often applied in the form of curves (Regression equation, e.g. buckling stress curves). Hypotheses and theories were developed based on empirical insights (deduction, induction). Over the last decades, the

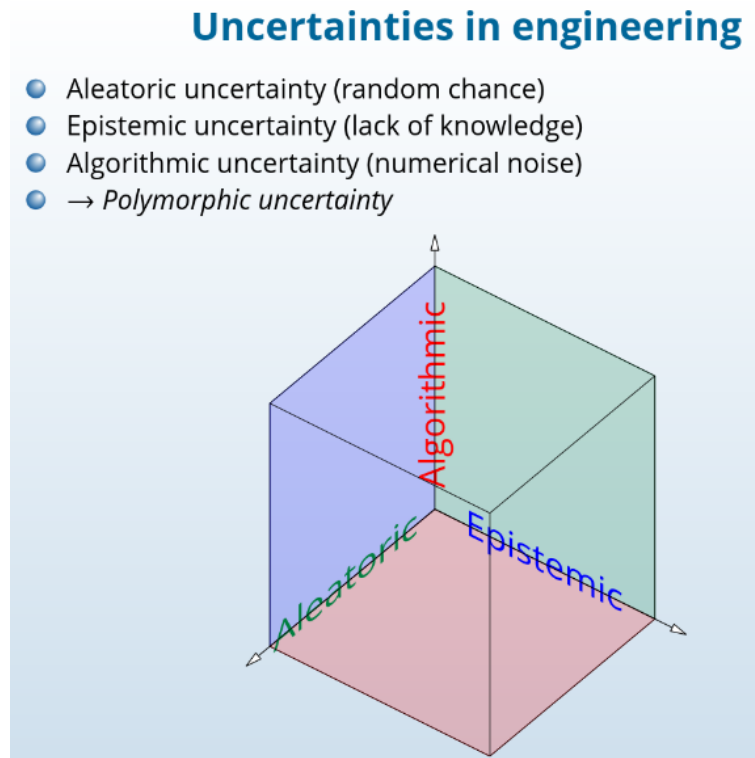

Figure 6: Uncertainties [Bucher, 2016]

theoretical model design, based on known physical laws (mechanics and mathematical description of parts or entire structures), is increasingly gaining in importance. Upon taking a closer look, it certainly becomes evident that empirical insights and models will remain of great use for some time to come (e.g. Young's Modulus E et al.)

In recent years methods of theoretical modelling, based on known physical laws (mechanic mathematical descriptions of parts or of the entire structure) increasingly gain importance. Looking closely, it can be observed that empirical insights and models (e.g. of great importance Young's Modulus E et al.) will remain useful.

The creation of models based on observation of the real world can be considered creation of basic models. Subsequently these form partial models (see Figs. 7-8). Fig. 13 presents this in a schematic diagram. Basic models generally are of an abstract nature and describe a single self-contained phenomenon. These tend to be either single, often empiric models, such as $\sigma = E \cdot \varepsilon$ or complex theories of mechanics, such as FE methods. Their logic consistency must be checked using verification methods.

This evaluation of consistency primarily includes basic usability within defined application boundaries, and the evaluation of the level of precision of the result data (verification + validation). The evaluation can be achieved via different methods, depending on the planned application area, and it also influences the model design approach. For instance, a representation of wind impact for high rises in structural engineering requires much simpler models than that for bridges or towers.

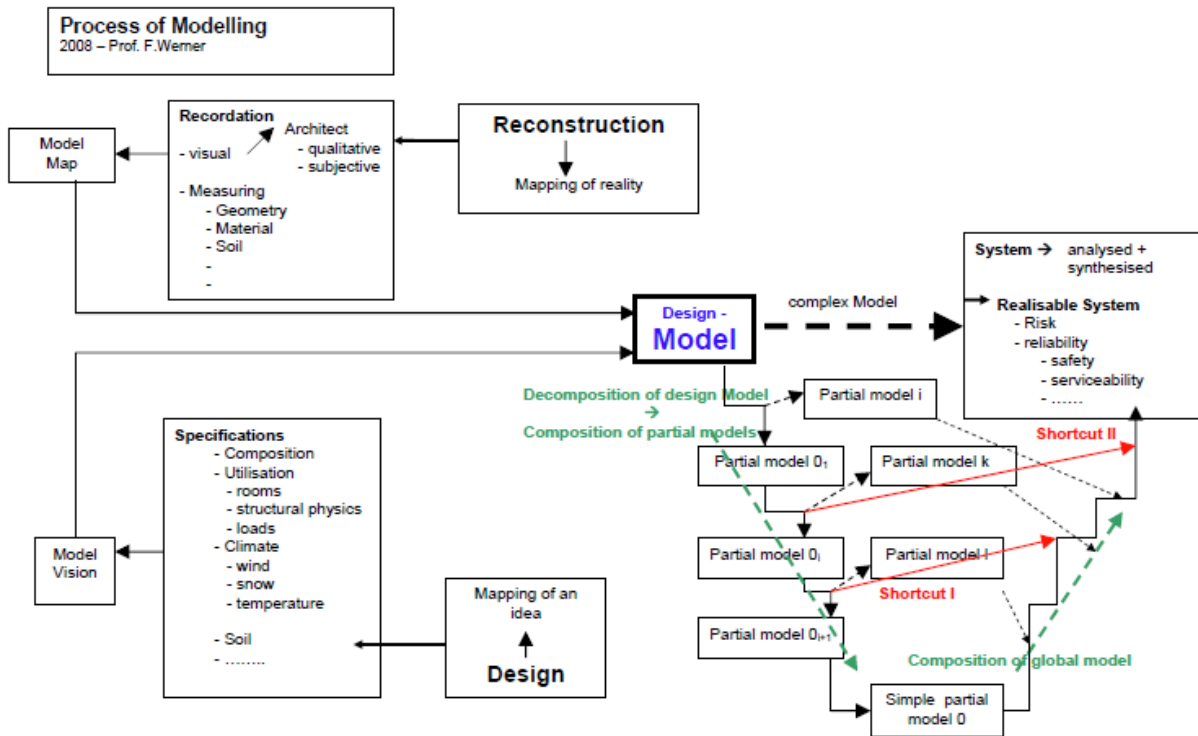

Figure 7: Interaction and coupling of partial models

A schema for coupling of partial models into global ones in order to describe a theoretical or practical task presents Fig. 7.

Global models generally should / must yield data that enables the creation of a product with a clearly defined confidence level. The regulating factor in this context is the aim to maximise economic efficiency. This creates evaluation criteria which evade an objective physical definition, such as energy minimum or limitation of deflections. An evaluation of the global model's quality must include:

- the properties of the partial models,
- their coupling methods, and
- the achieved results in the context of the created object in interaction with society.

Current discussions and differing views regarding the framework and content of the Eurocode provide an example for the difficulty of designing global models from different base models.

The trust in the predictive capability of a particular engineering model today remains largely based on the experience of the engineer.

The complexity of this task, still today determines the decomposition of the building tasks into a large set of sub-systems which have to be coordinated with each other (see

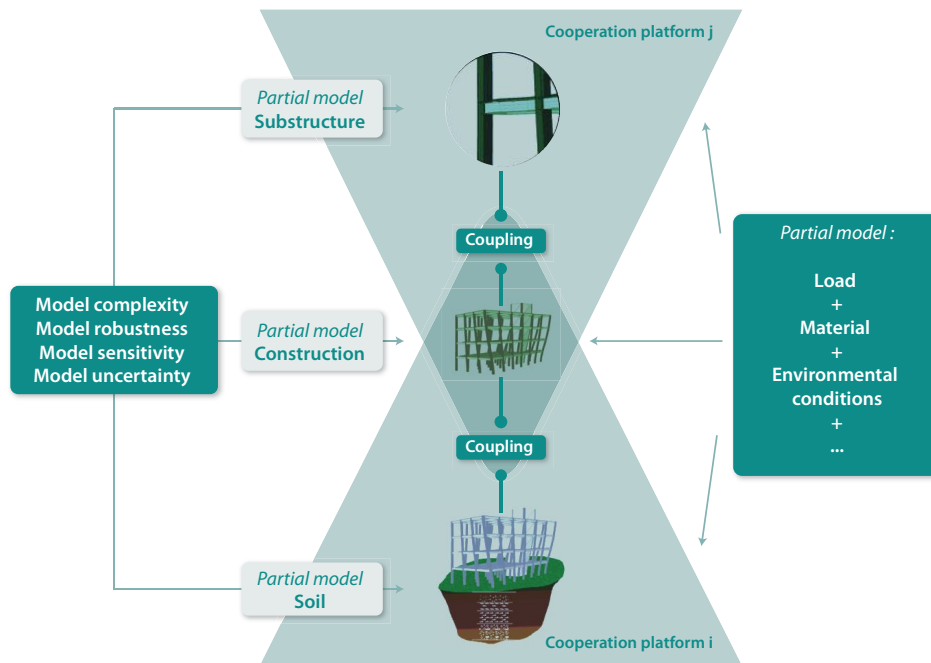

Figure 8: Partial and global model of a building task

Fig. 8). This results in an essential quality of models, respectively the problem areas these address:

- partial models \implies different types of models;
- coupling of models.

The definition and use of partial models is important, in order to analyse the quality of models. Often, structurally different models are coupled. The type of coupling becomes a determining factor regarding the value (i.e. quality) of the overall model.

Over time, some partial models will change. For instance, this can be a change of method due to new insights gained. Using computer based methods, several partial models are typically combined in a new development level into one more complex model (see Fig. 9).

A key problem relating to the evaluation of structures is that if these last over a long period of time, it is difficult to establish the reasons for their prolonged existence. Experiences regarding the economy or effectiveness of a construction method can often only be gathered on the verge to failure.

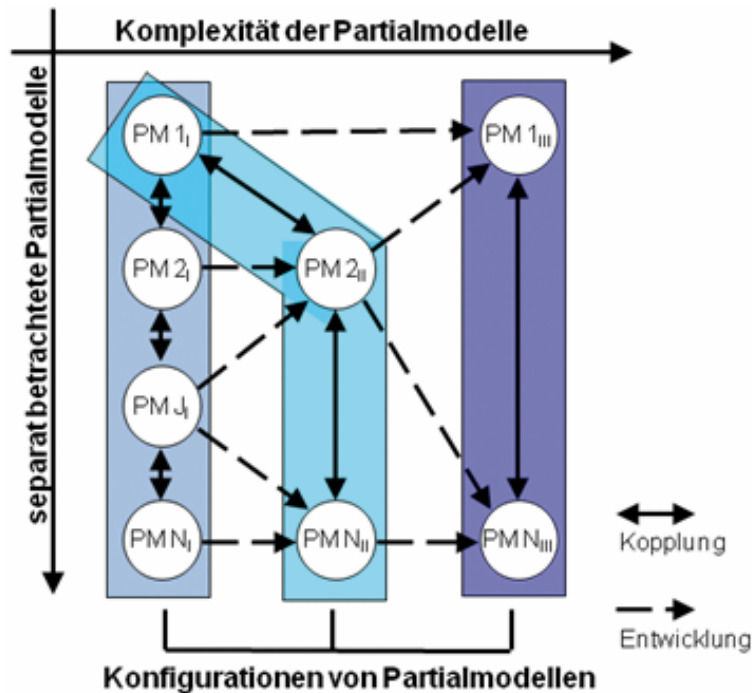

Figure 9: Configuration of partial models

The growing possibilities for the monitoring of structures will extend the pool of experience significantly in the future. For qualitatively new methods of failure research in practice little activity is undertaken.

Despite the availability of highly advanced analysis and synthesis software, failures still happen shortly after erection or reconstruction of buildings. For instance, uncoordinated changes to the galvanising material of steel structures lead to fractures, and hundreds of kilometres of Autobahn are currently made of a material which could crumble under the influence of water and de-icing salt.

These are known facts and require no further explanation. However, they need to be considered when attempting complex regulations. It is important to consider the stochastic character of key influencing variables (see Fig. 10).

A technical impact assessment is relatively difficult, not just for prominent buildings, as only a limited set of experience can be resorted to [9] and extrapolations based on complexity are tedious. For centuries, construction was based on the analysis of long-time practical experience, particularly after the negative experiences in the early turbulent years of industrialised construction. Until just a few years ago, construction was hence considered conservative. The construction industry sector was (and is?) considered a low-tech field.

The current market demands the use of new materials which often lack long term testing. It also defines new challenges with regard to size, weight and duration of the construction programme, etc. The economic competition requires effective, future proof

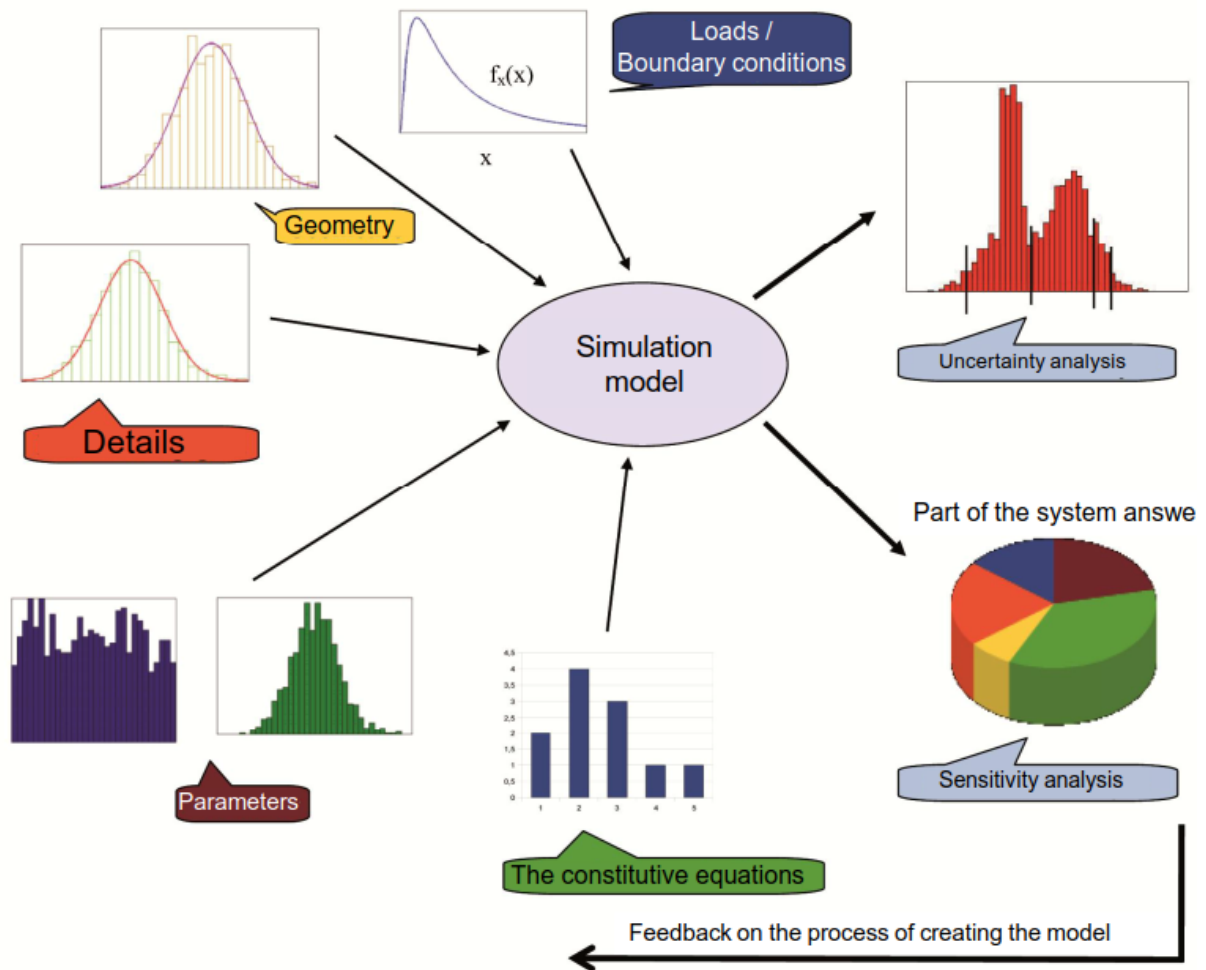

Figure 10: Simulation process with input values, based on [8] extended production methods and maintenance strategies.

3 Model and quality

While the term quality³ is used widely in everyday life, a problem-specific definition which meets engineering and scientific standards is practically impossible.

Considering the philosophical categories of Quality and Quantity, clear explanations can be found in works as early as Plato, Leibnitz, Kant and dialectical materialism today. The two terms are not contradictory. They tend to be used in tandem in the context of technical structures and processes.

In everyday language inexact expressions such as “good”, “bad”, etc. are not the focus of consideration⁴. Of the many meanings of the word “quality,” two are of critical importance to managing for quality:

1. “Quality” means those features of products which meet customer needs and thereby provide customer satisfaction. In this sense, the meaning of quality is oriented to income. The purpose of such higher quality is to provide greater customer satisfaction and, one hopes, to increase income. However, providing more and/or better quality features usually requires an investment and hence usually involves increases in costs. Higher quality in this sense usually “costs more.”
2. “Quality” means freedom from deficiencies—freedom from errors that require doing work over again (rework) or that result in field failures, customer dissatisfaction, customer claims, and so on. In this sense, the meaning of quality is oriented to costs, and higher quality usually “costs less.”

The different definitions highlight, that the term Quality can hardly be defined in a objective manner. In contrast, Quantity can easily be linked to objective assessments, such as amount, value or frequencies.

In order to capture and evaluate technical structures or processes and natural objects or phenomena data is required. This data can be obtained through observation. The

³Qualität (lat.: qualitas = Beschaffenheit, Merkmal, Eigenschaft, Zustand):

- neutral: die Summe aller Eigenschaften eines Objektes, Systems oder Prozesses
- bewertet: die Güte aller Eigenschaften eines Objektes, Systems oder Prozesses
- Grad, in dem ein Satz inhärenter Merkmale Anforderungen erfüllt: (Norm EN ISO 9000:2005 - gültige Norm zum Qualitätsmanagement), die Qualität gibt damit an, in welchem Maße ein Produkt (Ware oder Dienstleistung) den bestehenden Anforderungen entspricht
- Übereinstimmung zwischen den festgestellten Eigenschaften und den vorher festgelegten Forderungen einer Betrachtungseinheit (IEC – International Electrotechnical Commission — 2371)

Quantität (lat. quantitas: Größe, Menge):

- Menge oder Anzahl von Stoffen oder Objekten
- Häufigkeit von Vorgängen
- Wert oder Größe von Messdaten.

⁴Definition von Juran’s Quality Handbook, 5th edition, Joseph M Juran, A. Blanton Godfrey McGraw-Hill 1998

choice of observation methods, e.g. various types of measuring, has to ensure that the data these methods yield is objective. In that context the possibility of measurement errors, scattering, or inaccuracies has to be considered and discussed. The degree of truth, see for instance Popper $P1 \rightarrow VT \rightarrow FE \rightarrow P2$ ⁵, Hegel or Marx, etc. is of interest in this context.

As discussed, the data which has been gathered in various ways, forms the basis for a quantitative representation of the physical world (i.e. reality). Without systematic processing this data tends to be unusable for the formation of hypotheses and/or theories, and ultimately the creation of knowledge.

Any processing must be based on (partial) models. It cannot be assumed, that increasing (model) complexity also increases the objective character of the real world representation or reduces uncertainty more. Through FE (see above and footnote) gross distortions can be eliminated.

For instance, when measuring the gaps of car body panels (common example in the context of quality discussions), the gathered data is easy to process and to present. However, when structuring and summarising these findings, (e.g. what is better, a single greater discrepancy or discontinuous run) the choice of method is critical, if not using entirely subjective evaluation criteria.

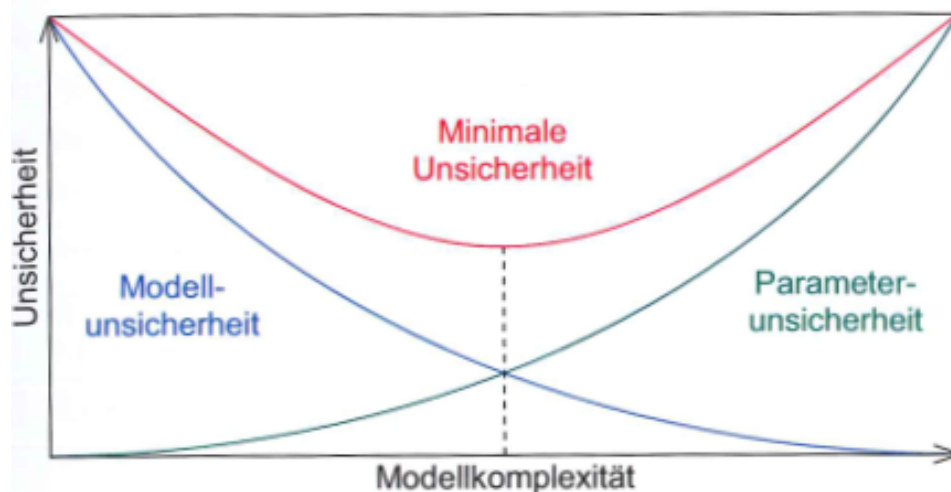

Figure 11: Complexity versus uncertainty

Only once a large enough amount of processed data for the observed object is available, this data can be used to derive the answers to key questions. In this context it must be

⁵Karl Popper, Objektive Erkenntnis, campe 1992 Hamburg, S. 310

Das Schema kennzeichnet den Fortschritt der Wissenschaft: Aufgrund eines Problems $P1$ aus der realen Welt erfolgt die Aufstellung einer zunächst rein hypothetischen Vorläufigen Theorie VT . Diese wird (z. B. empirisch) überprüft, unhaltbare Elemente in einer Fehlerelimination FE ausgeschieden. Das Resultat ist nicht ein absolutes Wissen, sondern ein elaborierteres Problem $P2$. FE setzt dabei voraus, dass logische Widersprüche vermieden werden müssen, da ansonsten eine Elimination von Theorieelementen, die in Widerspruch zu den bei der Theorieprüfung angeführten Argumenten stehen, nicht möglich ist.

considered that various different properties must be taken into account. The time period of observation plays a critical role in that context.

Following the forming of theories, or in early stages the development of hypotheses, natural processes or objects can be modelled mathematically or experimentally. Synthetic data can be gained from these models, and they can provide quantitative property prognoses. This data can and must include an evaluation with regard to its objective significance (practical test and veracity).

Evaluations of quality require a scale, in the form of a norm or a standard. This depends on the quality of the data and must have an objective capacity. In other words, **Quality is evaluated Quantity**.

The definition of degrees, limits or levels of this scale, which are derived from the obtained data, is subjectively influenced or even determined. The subjective experience gained from the comparison between data and reality plays a major part in this context⁶. The stochastic character of base data in interaction with model inaccuracies and any subjective influences on data processing or data interpretation can lead to a stipulation of quality which may not always reflect objective reality.

In this context, one of the three elementary laws of the dialectical materialism is applicable:

- Quantity changes to quality: a step change in the quality of an object occurs when the accumulation of quantitative changes reaches a certain limit.
- The language used in this expression is not quite exact – quantity cannot convert into quality \implies a modified data set describes a new situation which requires a modified scale, respectively a new evaluation of quality.

This corresponds with the observations of the real world under scientific and technical preconditions, and points to the great significance that is attributed to the description of qualities. If incorrect assessments are made, it becomes difficult to react to significant changes appropriately. The models which provide the basis for the production of the required data (quantities) have to be evaluated in view of their area of application (**sensitivity + robustness**). At times, it is necessary to utilise additional evaluations.

Definition 0.1. Model sensitivity: measure for the quantitative (where applicable qualitative) change of a model's outputs when changing parameters and input data.

Definition 0.2. Model robustness: measure for the model's ability to provide meaningful outputs for the parameter and input data, within a typically wide area of application in the field of construction .

⁶nach [https://de.wikipedia.org/wiki/Praxis_\(Philosophie\)](https://de.wikipedia.org/wiki/Praxis_(Philosophie))

Im 18. und 19. Jahrhundert fand der Praxis-Begriff Eingang in die philosophischen Systeme ... Karl Marx entwickelte den Praxis-Begriff zu einer philosophischen Kategorie mit präzisiertem Inhalt weiter: Daraus ergibt sich im Materialismus die Bedeutung von Praxis als Kriterium der Realität gegenüber jeglichen Theorien. Die Praxis korrigiert und bereichert die menschliche Erkenntnis... . Lenin definierte die Praxis in diesem Sinne als "Kriterium der Wahrheit". Er meinte damit vor allem die Verifikation von Theorien und deren Vereinbarkeit mit der realen Wirklichkeit (Praxis).

Definition 0.3. Model complexity: measure for the scope and the level of integration of physical laws or empirical links within the model and the resulting mathematical description, as well as the general usability and practicability for specific tasks.

Issues regarding the creation of models – modelling – based on different approaches or analysis models are being exempted in this paper (see Fig. 12). This is a vast field and any specific discussion depends on the objectives and expectations of the model outputs.

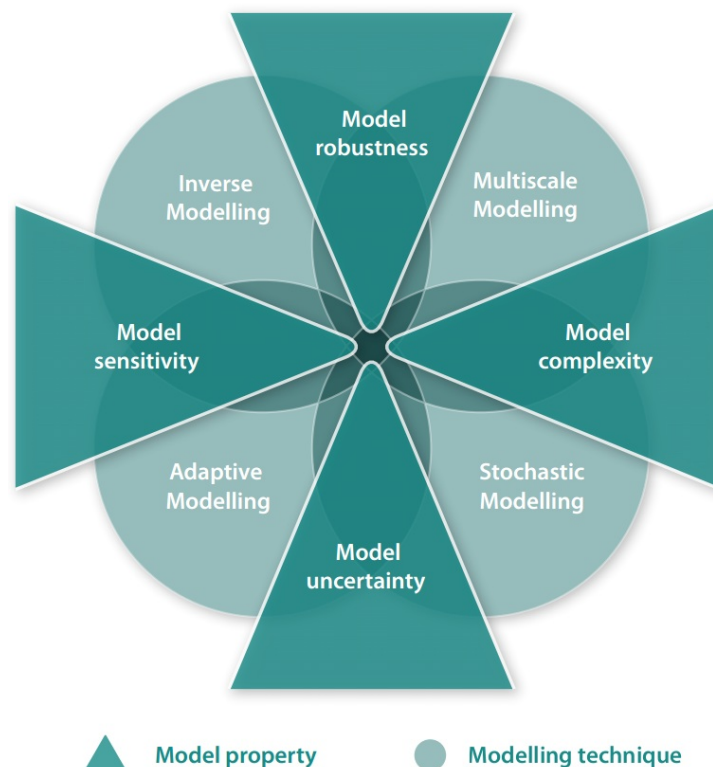

Figure 12: Characterization of models and types of modelling

The checking of models with regard to their informational value (quality?) in terms of representing and forecasting physical reality - Practice as touchstone of theory – is particularly complex in the field of the building sciences with its particular boundary conditions. Fig. 13 attempts to provide an overview of available options and recognised links.

It becomes evident that this effort can only be realised, at least in part, in the field of research and development. This leads to another challenge with regard to the practical use of models – models must be developed which can be verified and validated within given boundary conditions, but which are also reliable with regard to the boundary conditions discussed in section 2. This adds a further dimension to the quality issue.

In practice, quality is considered or defined within certain boundary conditions and expectations (see general definitions). On that basis an approach has been summarised under the term **”Measure of Merit”** (MoM).

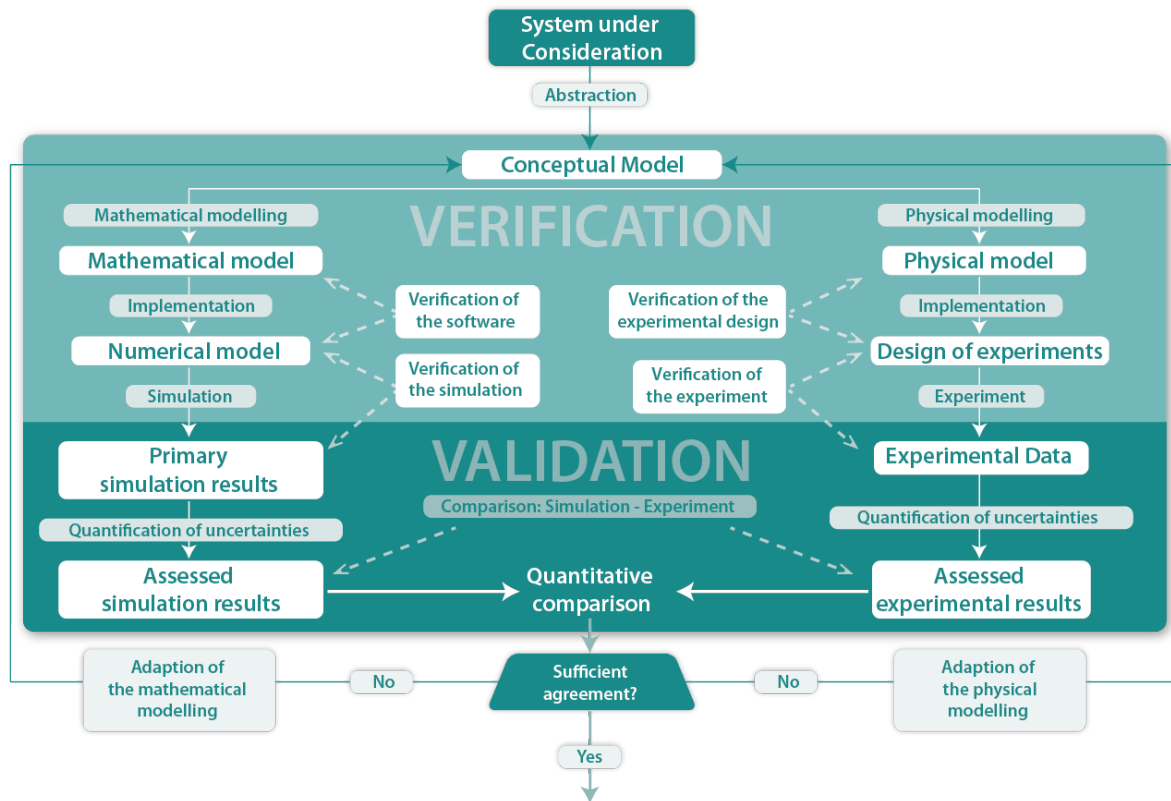

Figure 13: Organisation of global model assessment

MoM can cover quality, as well as the aim of the assessment (i.e. expectation). The abstract philosophical quality is translated into an applied term: Measure of Benefit, applicability and utility⁷.

This extension of the problem area does not form part of this paper as it is focused on specific practical processes, much more than discussed thus far. The same is true for the field of risk analysis. Quality of the planning models is critical. However, an impact assessment from an economic perspective is crucial.

4 Model evaluation

A detailed evaluation of models must distinguish between partial and global models. In the following, global models are generally considered coupled partial models. The evaluation of specific individual (partial) models is subject to less complex requirements.

⁷Nach <http://www.daswirtschaftslexikon.com/d/nutzwertanalyse/nutzwertanalyse.htm>
Die Nutzwertanalyse ist die "Analyse einer Menge komplexer Handlungsalternativen mit dem Zweck, die Elemente dieser Menge entsprechend den Präferenzen des Entscheidungsträgers bezüglich eines multidimensionalen Zielsystems zu ordnen. Die Abbildung der Ordnung erfolgt durch die Angabe der Nutzwerte (Gesamtwerte) der Alternativen." (Zangemeister, C. 1976, S. 45)

Ultimately, individual partial models can be split into a coupling of specific sub-models, to which similar considerations apply (see Fig. 9), as discussed in the following.

Questions regarding the evaluation of engineering models often tend to be limited to the relation between model output vs. in real world observed phenomena. This has been discussed in the previous sections. In summary, (at least) the following problem areas exist, in addition to the construction-specific problems:

- All key determinants are of a stochastic character and measurement data is generally only available for shorter time periods for an existing building.
- Little usable data is available for objects (buildings) that have surpassed a theoretically planned life time:
 - either these objects continue to exist — used approaches have been too favourable;
 - or objects have not reached the expected use life – approach not realistic, causes can not be clearly described.
- Coupling of stochastic partial models leads to a model quality of a highly complex character. Outputs will always have to be based on attributes.
- The outputs of Experiments (AOI + ROI) also contain errors, which need to be considered as part of the evaluation.

As the determination of quality levels is of a subjective character (see Section 3), at least the definition of evaluation criteria requires objective procedures (see Fig. 14).

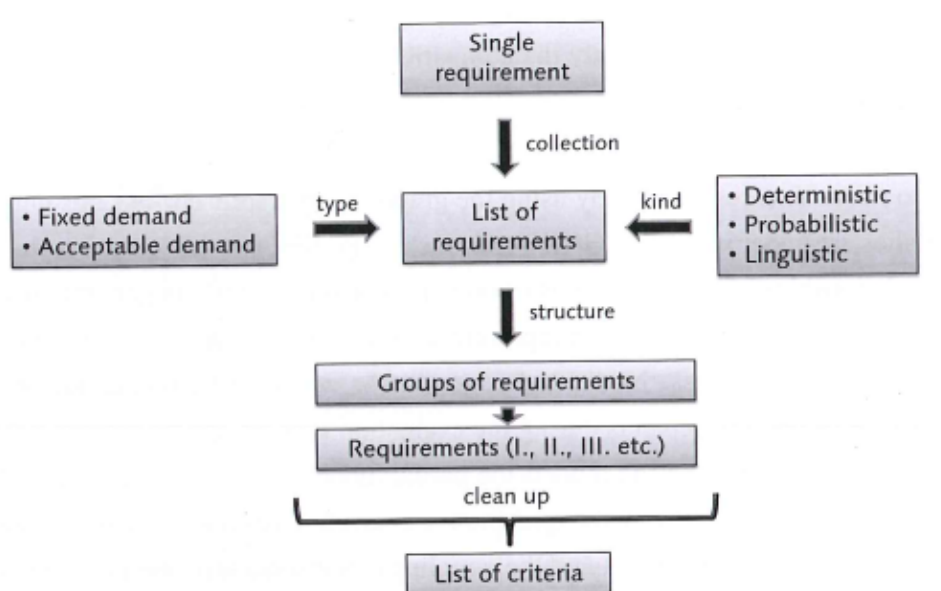

Figure 14: Criteria for model assessment

A possible structure, specific to civil engineering, is shown in Fig. 16. A structure for architectural issues would look distinctly different. Specific application scenarios might also require the choice of different or additional criteria. This dependence of the evaluation criteria on the specific area of application complicates the discussion regarding model quality significantly.

For a global model used in an actual construction process, generally the following approaches for the assessment of model quality can be distinguished:

- Evaluation of the whole theoretical model
 - In practice this tends to be the only feasible approach, as usually a comparison with experimental data is not possible (practice as touchstone of truth);
 - It is aimed for an assertion regarding the reliability of model outputs considering the requirements, respectively a comparison of model outputs using different coupled partial models.
- Evaluation of experimental models
 - This approach in its "pure" form is currently only applied in few fields any more, such as wind tunnels, hydrology, etc. Ultimately today it is always aimed at a comparison between measured and calculated data;
 - Construction monitoring can be understood as a form of (post) experimental model evaluation.
- Hybrid models
 - These approaches, to compare data gathered from theoretical global models with data from experimental models (AOI+ROI), is the only way to compare theory and reality as realistically as possible. In construction practice this is limited to special applications, as the effort for "normal" buildings is hardly feasible for economic, as well as time reasons.
 - For the evaluation it is important to consider that ROI-experiments are also only a representation of reality.

These considerations are also dependent on the importance of the project, or the purpose of investigations.

For these approaches research in different problem areas and with different coupled partial models was undertaken. For a standard design process, generally no measurement data (physical quantities) is available as a basis for comparison. Due to this fact, an evaluation process entirely based on mathematical model data has to be used, see e.g. [4, 5, 6]. The approach in [6] constitutes a general approach under consideration of many influencing parameters. In this context, an experience-based comparison will always have a more or less subjective slant.

The term "theoretical model" is to be understood as global model which is considered for a specific application. This can also be considered in an abstract manner, i.e.

as an example or a principle, such as the design of a multi-storey building with defined environmental factors. This is usually done by coupling several partial models - actions, materials, subsoil, mechanics, etc. – in order to process the input data and obtain dimensions for the building parts. The type and coupling of the partial models depends on the available partial models and the preferences of the responsible engineer.

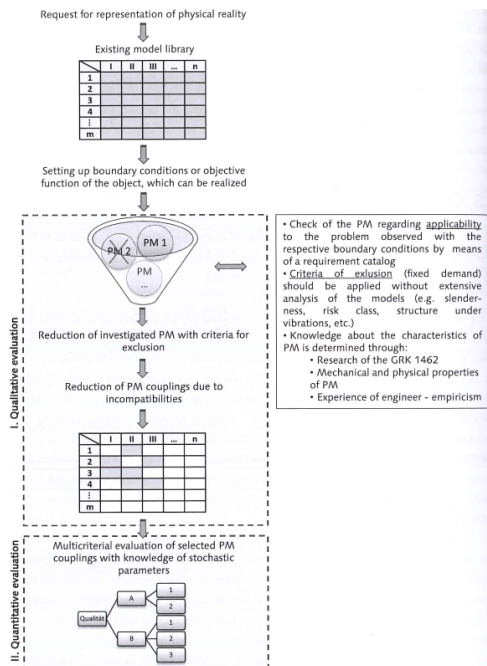

Figure 15: Principal algorithm for a theoretical model assessment

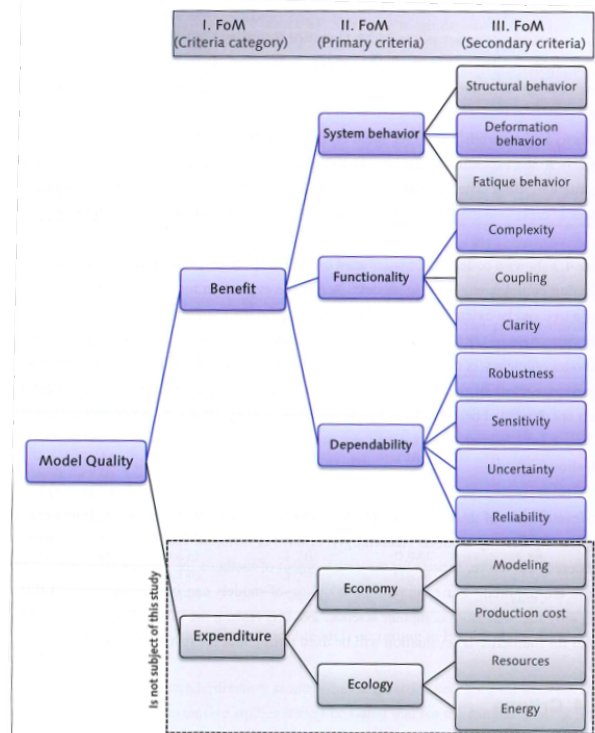

Figure 16: Criteria for assessment of engineering models

The term theoretical model tends to be mainly associated with mechanical models in day to day use, such as FE models. The quality of the mechanical partial model by itself impacts the quality of the global model. The evaluation methods for theoretical models in mechanics are known. The procedures, despite great diversity of methods, are focused on abstract error estimates. Reality as measure of value is reduced to an energy difference. This problem area is not the focus of this discussion.

A mathematical approach for the model evaluation in this case presents the reduction of the overall model uncertainties, which consist of model and parameter uncertainty [30]. Here the evaluation process is based on the combination of different sub-models, which are linked into one coupled model. Within each class of models the most complex model is assigned model quality one and simpler models are assigned lower quality levels.

The couplings play an important role for the quality of global models. Capturing their effects in a general method is difficult and research in this field is still in its infancy [28]. A practical approach is discussed in [4]. Using sensitivity analyses (see [6]) to establish the impact of the respective partial models and model classes can facilitate an evaluation

of different model couplings. The quality of the couplings themselves might be assessed via a subjectively influenced evaluation (see Fig. 17).

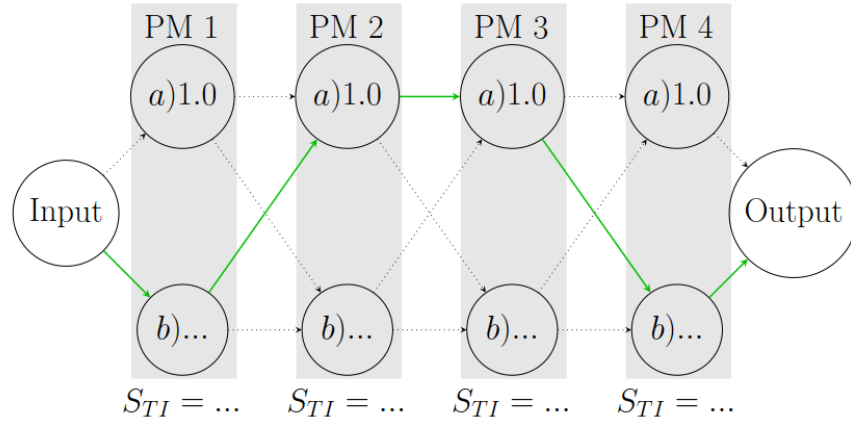

Figure 17: Scheme of quality assessment of coupled global models

The comparison of the outputs from theoretical and experimental models (Fig. 13) creates a way of evaluating both types of models. One method for this is presented in [7]. It is termed model coupling in this paper. However, actually it is an assessment of model outputs under consideration of the stochastic properties of both parts. The uncertainties around the outputs of physical models tend to be underestimated. When working near the limit state of the model, even experimental data can often not be clearly interpreted. An impressive example for this are slender beams, which are near the load carrying capacity.

5 Conclusion

The assessment of quality for global models is highly dependent on the specific requirements of the expected model output data. Even for problems that are smaller or rather common, a subjective definition by the model user is a significant criterion for the definition of quality levels.

As expected, a general method for the evaluation of engineering models could not be established. Standardized values of reliability levels or constructive rules (e.g. in the ECs) require in many cases comprehensive scientific processing.

The quality of global models will experience a significant change over the coming years, due to the new possibilities of creating increasingly complex systems of building parts. In this context, evaluating the interaction of partial models will become progressively important. At the same time, tools must be created, which allow the evaluation of highly complex models using simplified review schemes. This ensures the identification of incorrect or even wrong models.

Research into the quality of global models in the field of engineering structures has only just started.

References

- [1] B. Novak, Die historische Entwicklung des Knickstabproblems und dessen Behandlung in den Stahlbaunormen, *Heft 35, Veröffentlichung des Instituts für Statik und Stahlbau der TH Darmstadt*, 1981.
- [2] M. Mayer, *Die Sicherheit der Bauelemente und ihre Berechnung nach Grenzkraften anstatt nach zulässigen Spannungen*, Berlin 1926.
- [3] U. Weyer, Anspruch und Wirklichkeit semiprobabilistischer Bemessungskonzepte, *Stahlbau*, 73, S. 745 – 753, 2004.
- [4] H. Keitel, G. Karaki, T. Lahmer, S. Nikulla, V. Zabel, Evaluation of coupled partial models in structural engineering using graph theory and sensitivity analysis, *Eng. Struct.*, 33 (12) 3726–3736, 2011.
- [5] T. Most, Assessment of structural simulation models by estimating uncertainties due to model selection and model simplification, *Comput. Struct.*, 89 (17–18), 1664–1672, 2011.
- [6] M. Reuter, F. Werner, Evaluation of complex engineering models using model quality analysis, *Eng. Struct.*, 42, 410–419, 2012.
- [7] F. Scheiber, H.B. Motra, D. Legatiuk, F. Werner, Uncertainty-based evaluation and coupling of mathematical and physical models, *Probabilistic Engineering Mechanics*, 45, 52–60, 2016.
- [8] A. Saltelli, Sensitivity-Scheme, http://en.wikipedia.org/wiki/File:Sensitivity_scheme.jpg, May 1999.
- [9] M. Bauer, M. Reuter, Realität—Experiment—Simulation: Untersuchungen am Beispiel eines Biegeträgers, in: *Deutscher Ausschuss für Stahlbau DAST (Ed.) 17. DAST-Kolloquium in Weimar, Frehner, Düsseldorf*, pp. 31–35, 2010.
- [10] H.-J. Bungartz, S. Zimmer, M. Buchholz, D. Pflüger, *Modellbildung und Simulation*, Springer, Berlin, 2009.
- [11] M. Huber, Reducing forecast uncertainty by using observations in geotechnical engineering, in: *Proceedings of the 12th International Probabilistic Workshop, Bauhaus-Universität Weimar*, Schriftenreihe DFG Graduiertenkolleg 1462, vol. 11, University Press, Weimar, pp. 110–118, 2014.
- [12] JCGM: Joint Committee for Guides in Metrology, *Guide to the Expression of Uncertainty in Measurement (GUM)*, JCGM 100, 2008.
- [13] JCGM: Joint Committee for Guides in Metrology, *Guide to the Expression of Uncertainty in Measurement—Supplement 1: propagation of distribution using the Monte Carlo method (GUMS1)*, JCGM 101, 2008.

- [14] JCGM: Joint Committee for Guides in Metrology, *Evaluation of Measurement Data—The Role of Measurement Uncertainty in Conformity Assessment*, JCGM 106, 2012.
- [15] JCSS: Joint Committee on Structural Safety, *Probabilistic Model Code (Parts 1–3)*, 12th Draft 2001.
- [16] H. Keitel, A. Dimmig-Osburg, L. Vandewalle, L. Schueremans, Selecting creep model using Bayesian methods, *Mater. Struct.*, 45 (10), 1513–1533, 2012.
- [17] A. Saltelli, M. Ratto, T. Andres, F. Campolongo, J. Cariboni, D. Gatelli, M. Saisana, S. Taran-tola, *Global Sensitivity Analysis: The Primer*, Wiley, Chichester, 2008.
- [18] F. Scheiber, H.B. Motra, D. Legatiuk, F. Werner, Model Coupling in Structural Engineering Application, in: *Proceedings of the 12th International Probabilistic Workshop, Bauhaus-Universität Weimar*, Schriftenreihe DFG Graduiertenkolleg 1462, vol. 11, University Press, Weimar, pp. 283–292, 2014.
- [19] K. Klöppel, Rückblick und Ausblick auf die Entwicklung der wissenschaftlichen Grundlagen des Stahlbaues, *Abhandlungen aus dem Stahlbau*, Düsseldorf (1948) 2, S. 48-72.
- [20] F. Werner, J. Seidel, Der Eisenbau – Vom Werdegang einer Bauweise, *Verlag für Bauwesen*, Berlin 1991.
- [21] K.-E. Kurrer, Stahl + Beton = Stahlbeton, *Beton- und Stahlbetonbau*, 92, Heft 1, S. 45, 1997.
- [22] K.-E. Kurrer, 100 Jahre Normen im Stahlbetonbau, *Beton- und Stahlbetonbau*, 98, Heft 12, S. 794, 2003.
- [23] H. Duddeck, Entwicklung der Berechnungsmodelle des Bauingenieurs: Woher? Wohin?, *Bautechnik*, 70, S. 640-649, 1993.
- [24] H. Duddeck, Wie konsistent sind unsere Entwurfsmodelle?, *Bauingenieur*, 64, S. 1–8, 1989.
- [25] E. Hampe, Exakte Tragwerksberechnung — Faszination oder Illusion?, *Bauingenieur*, 66, S. 1-9, 1991.
- [26] E. Hampe, Von der unsicheren Sicherheit zur sicheren Unsicherheit, *Bautechnik*, 66, S. 329 -335, 1989.
- [27] F. Werner, Normen — Wegbereiter und Hindernis in der Entwicklung des Stahlbaues, *100 Jahre Deutscher Ausschuss für Stahlbau*, Düsseldorf 2008.
- [28] K. Gürlebeck, D. Hofmann, D. Legatiuk. Categorical approach to modelling and to coupling of models, *Mathematical Methods in the Applied Sciences*, 2016, DOI: 10.1002/ma.3978.

Interaction modeling in mechanized tunneling

Günther Meschke¹

1: *Ruhr University Bochum, Institute for Structural Mechanics, guenther.meschke@rub.de*

Abstract. Mechanized tunneling is an established flexible and efficient technology for the construction of underground infrastructure. To ensure high quality standards and to limit the risks during tunnel construction, realistic and reliable numerical models are required, which have proven prediction capabilities for the design and the construction stages of a tunnel project, in particular in difficult geotechnical conditions and sensitive urban environments. Considering this background, the Collaborative Research Center SFB 837 “Interaction Modeling in Mechanized Tunneling” has been installed by the German Research Foundation in 2010 at Ruhr University Bochum, Germany. The focus of the SFB 837 is the research and development of models, numerical and experimental methods and design concepts, which, when adequately interlinked, can deal with the manifold complex interactions of the components (ground, shield machine, support measures, tunnel lining, existing buildings) and processes (advancing and excavation process, construction operation) involved in mechanized tunneling.

In the presentation, selected topics related to the modeling of specific components involved in mechanized tunneling are presented. The topics are chosen such as to demonstrate the interaction between different sub-models. On the scale of the tunnel construction, a process oriented computational model (ekate) for the stepwise advancement of the machine driven tunneling advance is presented. More specifically, the generation of complex models using a Tunnel Information Model (TIM) for the automatized finite element model generation is addressed. Since in urban tunneling, the interaction between existing structures and the tunnel construction is essential, suitable substitute models for the buildings are developed and coupled with ekate, considering different degrees of complexity. In the final part of the presentation, the numerical design of segmented linings is addressed. It involves a multi-level model for fiber reinforced concrete, which transfers information from the scale of the individual fiber to the structural scale. Different lining designs and the cracking processes are simulated numerically evaluated in terms of serviceability and ultimate loading capacity.

Efficient reliability analysis of systems in uncertain environments

Michael Beer¹

1: *Institute for Risk and Reliability, Leibniz Universität Hannover, Germany*

Institute for Risk and Uncertainty, University of Liverpool, UK

International Joint Research Center for Engineering Reliability and Stochastic Mechanics, Tongji University, Shanghai, China

Abstract. Engineering systems are characterized by a rapid growth in scale and complexity. The amount of information needed to model these systems with their complexity is, thus, growing as well. In contrast to this increasing need for information the available information remains almost at the same level. Hence, with increasing scale and complexity the gap between required and available information is growing quickly, so that uncertainties and risks are involved in our models and analyses to a greater extent than ever before. In particular, epistemic uncertainties become involved to a significant extent. There is a clear consensus that these epistemic uncertainties need to be taken into account for a realistic assessment of the performance and reliability of our systems. However, there is no clearly defined procedure to master this challenge. The second challenge is to analyze large systems under consideration of uncertainties efficiently. These two challenges are addressed with focus on imprecise probabilities and in the context of system reliability assessment. Numerically efficient concepts are discussed. Engineering examples are presented to demonstrate the capabilities of the approaches and concepts.

Recent advances in thunderstorm downbursts: field measurements, weather survey, laboratory tests, numerical simulations and loading of structures

Giovanni Solari¹

1: University of Genoa, Polytechnic School, Department of Civil, Chemical and Environmental Engineering (DICCA), Via Montallegro 1, 16145 Genoa, Italy, giovanni.solari@unige.it

Abstract. Thunderstorm downbursts and their loading of structures are dominant topics of wind engineering. The European Projects “Wind and Ports” and “Wind, Ports and Sea” contribute to the growth of their knowledge through the realization of an extensive wind monitoring network that transfers the measured data to the central server at DICCA where a huge database is assembled. Here, a method has been implemented to extract and analyse wind records detected during thunderstorm downbursts. Parallel evaluations are carried out to study the weather scenarios in which thunderstorms occur, to replicate these in wind tunnels and by CFD, to estimate their extreme value distributions. Two alternative methods have been formulated to determine the thunderstorm loading of structures. The first, oriented to engineering and code applications, is an evolution of the response spectrum technique. The second is based on time-domain integrations of the equations of motion starting from the hybrid simulation of thunderstorm wind fields. These methods are encapsulated into the Independent Wind Loading Technique, a novel criterion for evaluating the wind loading of structures in mixed climates.

1 Introduction

The study of thunderstorm downbursts and their actions on structures is a dominant topic of recent research in wind engineering [1, 2]. This mainly depends on the fact that the methods used to determine wind actions on structures are still mostly based on the model developed by Davenport [3] for the stationary phenomena at synoptic scale that occur in neutral atmospheric conditions, with velocity profiles in equilibrium with the atmospheric boundary layer (ABL). Thunderstorms are non-stationary phenomena at mesoscale that occur in convective conditions with “nose” velocity profiles totally different from those that are typical of the ABL (Figs. 1 and 2). Design wind velocities are often associated with thunderstorm events (Fig. 3).

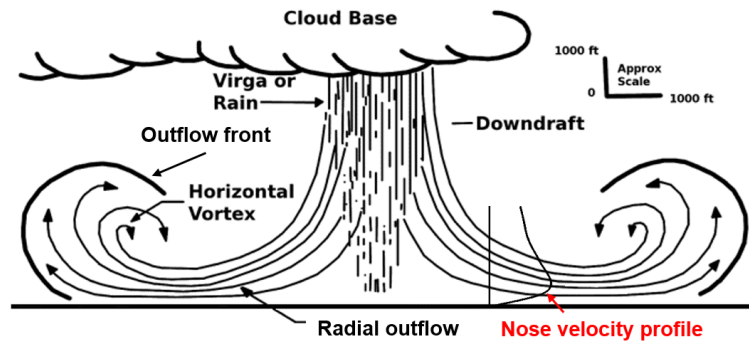

Figure 1: Scheme of a thunderstorm downburst and its nose velocity profile in the radial outflow

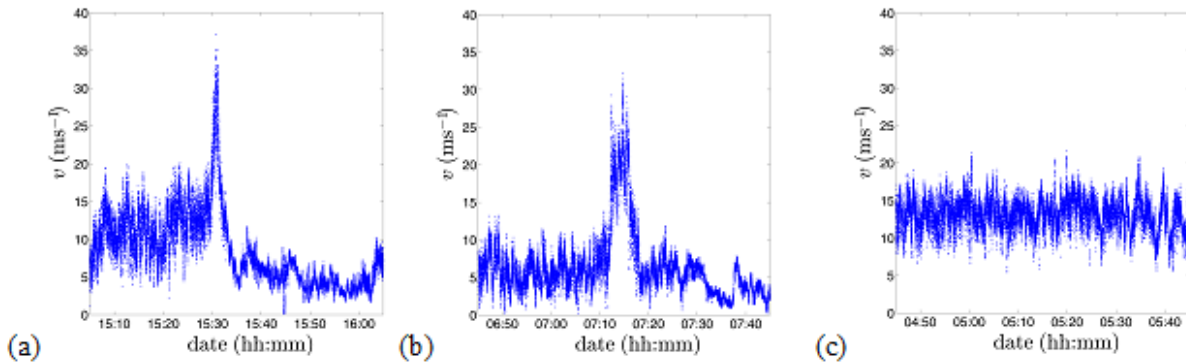

Figure 2: Wind velocity records detected in the Port of La Spezia: thunderstorm outflows recorded on October 25, 2011 (a) and April 11, 2012 (b); synoptic extra-tropical cyclone recorded on October 7, 2011 (c)



Figure 3: Consequences of the thunderstorm downburst occurred in the Port of Genoa on 31 August 1994

2 Wind monitoring and thunderstorm outflow database

The European Projects “Wind and Ports” [4] and “Wind, Ports and Sea” [5], carried out by author and his research group, contribute to the growth of the knowledge of thunder-

storm downbursts and their effects on the built environment [6]. These projects developed an extensive monitoring network that generated a huge database of anemometric data, the numerical simulation of wind fields, wind climate analyses, algorithms for medium-term (1-3 days) wind and wave forecasts as well as algorithms for the short-term (0.5-2-hour) wind forecast in the ports of Genoa, Savona, La Spezia, Livorno and Bastia.

The monitoring network is made up of 24 ultrasonic anemometers, 3 weather stations, each one including an additional ultra-sonic anemometer, a barometer, a thermometer and a hygrometer, and 3 LIDARs (LIght Detection And Ranging) (Figs. 4 and 5). It is continuously upgraded by new sensors owned by private companies and local authorities that recognize the crucial importance of detecting the wind and contribute to make the monitoring network more and more robust, extensive and shared in port communities.

A set of servers placed in each port involved in the European Projects receives the measurements, elaborates the basic statistics on 10-min periods, and sends the information to the central server at DICCA. This server stores the raw data and the statistical values in a central database, after having systematically checked and validated the data. A procedure has been implemented [7] to extract and separate different intense wind events. While literature tends to apply a simple binary separation of stationary Gaussian synoptic events and non-stationary non-Gaussian thunderstorms, the registered data point out the presence of stationary non-Gaussian intermediate events that make the above separation a critical issue.

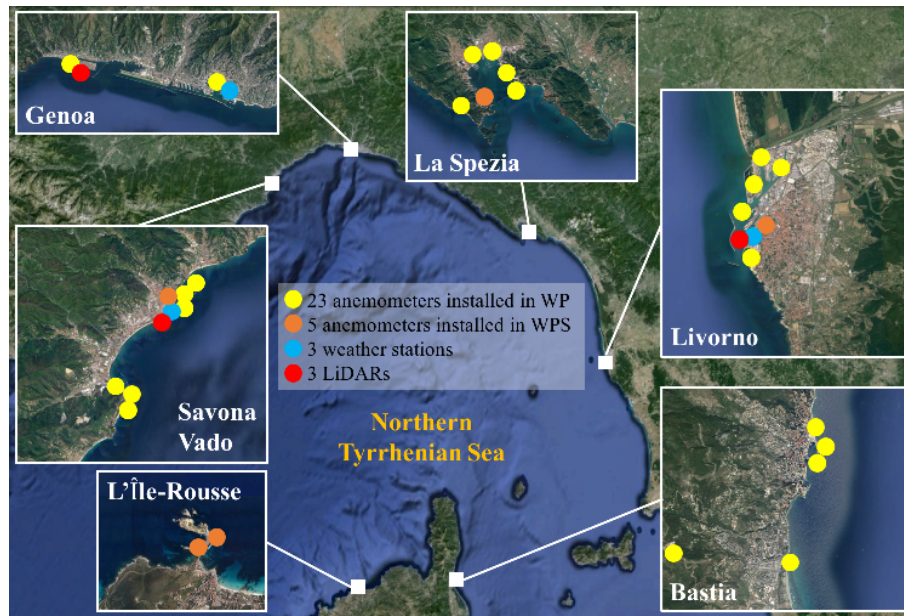

Figure 4: Wind monitoring network



Figure 5: Wind monitoring network: three-axial and bi-axial ultrasonic anemometers

3 Thunderstorm outflow modelling and simulation

Each thunderstorm velocity record is decomposed into the the sum of its slowly-varying mean part, averaged on a 30-s moving average period, plus a residual fluctuation given by the product of its time-varying standard deviation multiplied by a random stationary Gaussian signal with zero mean and unit standard deviation. The main parameters of each record and its component parts are gathered and analyzed in the frame of probabilistic analyses aiming to determine the downburst scale and duration, its turbulence properties, the spectral content of the fluctuations, and the gust factors [8]. Similar evaluations are carried out in respect of the first measurements obtained by means of LIDARs (Fig. 6). They provide the spatio-temporal evolution of the wind velocity profile between the heights of 40 and 250 m [9].

In parallel evaluations are currently carried out with the aim of framing the weather scenarios in which thunderstorm records are detected by the monitoring network (Fig. 7), using model analyses, standard in-situ measures, remote sensing techniques, proxy data, and direct observations (Fig. 8) [10]. They have the purpose of sorting the wind velocity records according to homogeneous families associated with different meteorological phenomena and provide perspective indications on the precursors of such events.

At the same time there is a broad collaboration between the University of Genoa and the WindEEE Research Institute at the University of Western Ontario, where the world's largest laboratory for the simulation of large-scale downbursts has been realized. In this framework numerous simulations of thunderstorm downbursts are in progress whose wind fields will be compared with field measurements (Fig. 9). The aim is, on the one hand, to validate and improve the representativeness of the downbursts simulated in the laboratory, and, on the other hand, to fill the information provided by the monitoring network by means of measurements carried out in a set of discrete points.

Preliminary estimates are also carried out to determine the probability of occurrence of the extreme wind speed associated with the thunderstorm events recorded by the monitoring network [11].

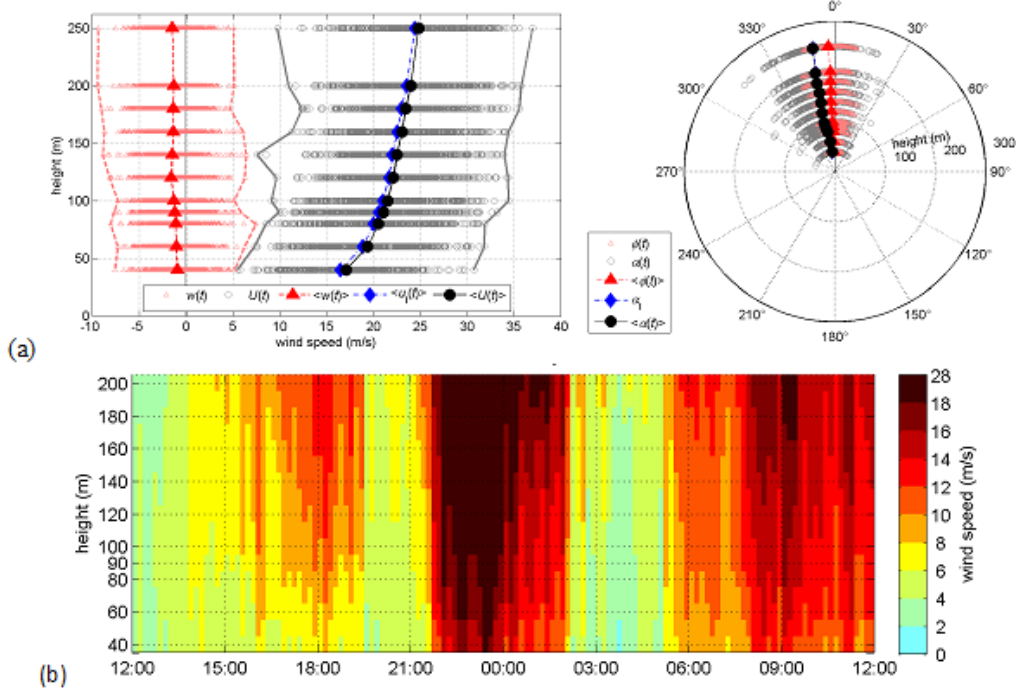

Figure 6: Intense synoptic event as detected by LIDAR in the Port of Savona on 4 March 2015: a) 10-min mean wind velocity and direction profiles; b) 24-h time histories of horizontal mean wind velocity profiles

4 Thunderstorm loading and response of structures

The ultimate goal of this set of evaluations is to create a wind model of thunderstorm downbursts and their loading of structures that could constitute the counterpart of the model widely used in the literature to represent the extra-tropical cyclones at the synoptic scale [3].

Meanwhile, preliminary models of the wind loading of structures and their response have been developed, giving rise to two alternative methods. The first one, oriented to engineering and code applications, applies an evolution of the response spectrum technique widely diffused in the seismic sector. This technique was first developed for single-degree-of-freedom systems subjected to ideally coherent wind fields (Fig. 10)[12], then it was extended to multi-degree-of-freedom systems subjected to real partially coherent wind fields [13]; on this basis equivalent static actions were also introduced. The second method applies time-domain integrations of the equations of motion based upon the hybrid simulation of wind fields consistent with the above thunderstorm data (Fig. 10) [14]. Cross-comparisons are currently in progress to jointly validate and upgrade both these methods.

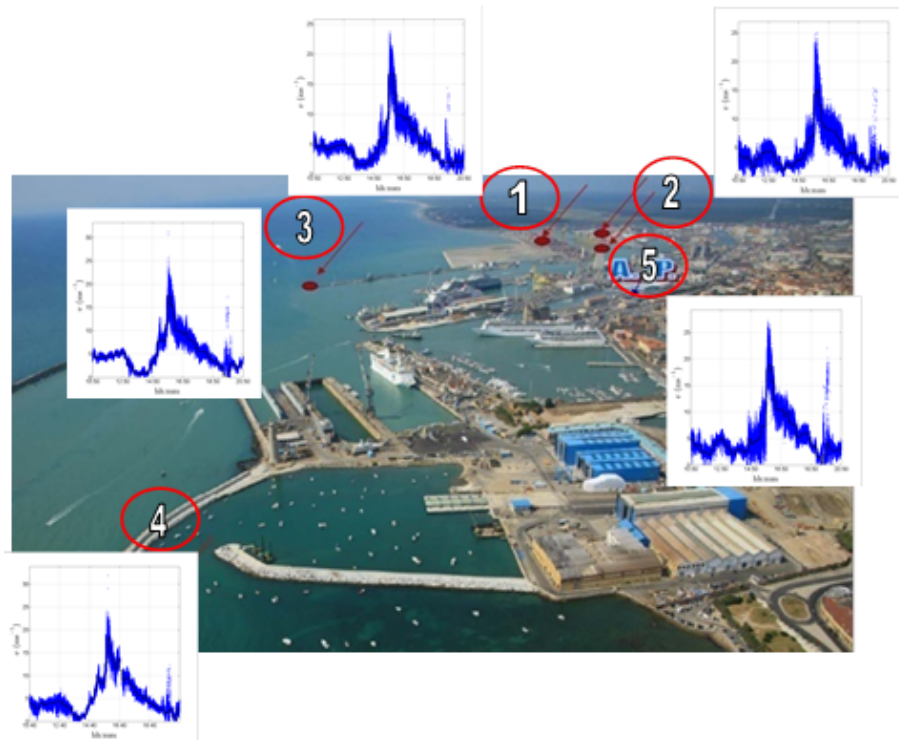

Figure 7: Port of Livorno, 4 September 2011, thunderstorm downburst

5 Independent Wind Loading Technique

The equivalent static actions of thunderstorms are embedded in a new approach, the Independent Wind Loading Technique [2], aimed at establishing a new criterion for evaluating the wind loading of structures in mixed climates. In place of the classical unique wind loading condition that joins different wind phenomena through mixed statistics, this technique gives rise to as many independent wind loading conditions as the wind phenomena that characterize the mixed climate, first of all the synoptic and thunderstorm events.

This approach is robustly supported by the deep diversity of these events with reference to the stationary or non-stationary and Gaussian or non-Gaussian character of the wind velocity, the shape of the velocity profiles, the parameterization of the wind fields with regard to the roughness length and the thermal stratification, the intensity, size, duration and frequency of these events.

The different intensity, size, duration and frequency of synoptic and thunderstorm events points out that they do not lend themselves to be represented by the unique set of partial and combination factors usually adopted with reference to the classical unique wind loading condition. Diversifying this loading into a set of independent wind loading conditions leads to the striking proposal of revisiting the actual combination rules of the loadings, at least introducing diversified sets of wind partial and combination factors [2].

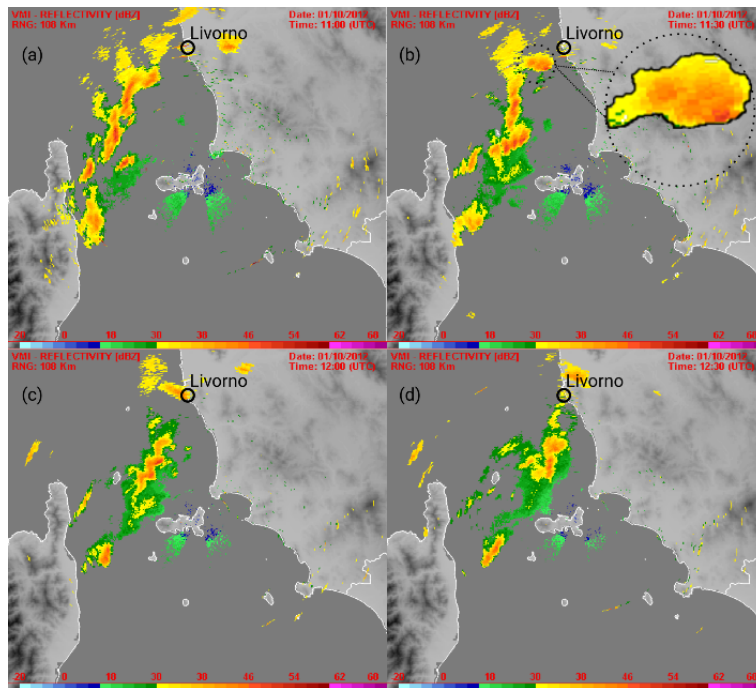

Figure 8: Reflectivity (dBZ, Vertical Maximum Intensity) measured by the meteorological X-band radar, installed at Cima di Monte (Elba Island) at 480 m ASL, at 1100 (a), 1130 (b), 1200 (c), and 1230 UTC (d), (courtesy LaMMA Consortium)



Figure 9: Inner chamber of the WindEEE Dome and a simulated downburst, (courtesy University of Western Ontario)

6 Conclusions and prospects

Wind, structural and civil engineering communities are slowly but inexorably realizing that intense wind speeds and heavy wind damage are often related to thunderstorm outflows rather than to the synoptic phenomena over which scientific, technical and codification methods are founded from over half century. This research is aiming to strengthen an unprecedented monitoring network, to collect a huge amount of field data, to interpret weather and damage scenarios, to conduct unique large-scale wind tunnel tests and CFD simulations, to develop new models of thunderstorm outflows, loading and response of structures, to design wind-safer and cost-efficient structures up to producing a deep

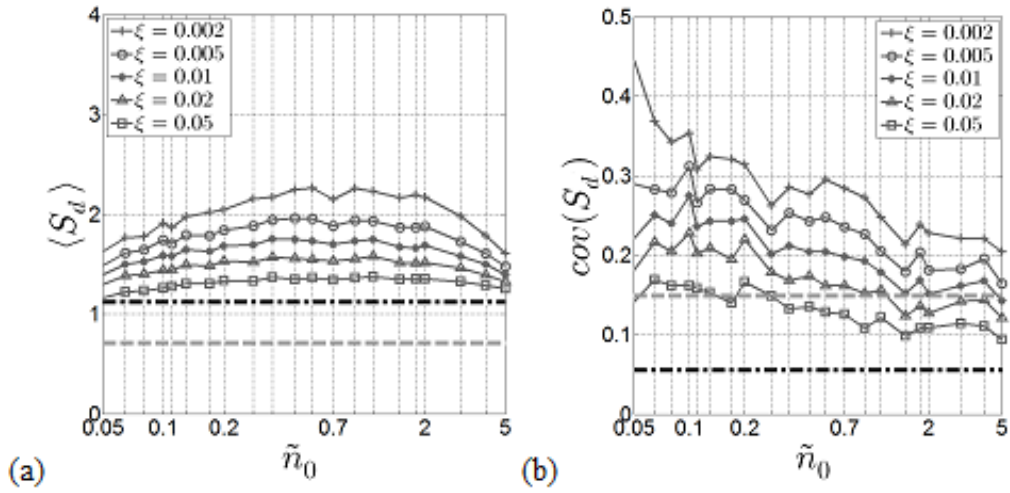

Figure 10: Mean (a) and cov (b) of the response spectrum as a function of the reduced fundamental frequency and the damping coefficient ξ

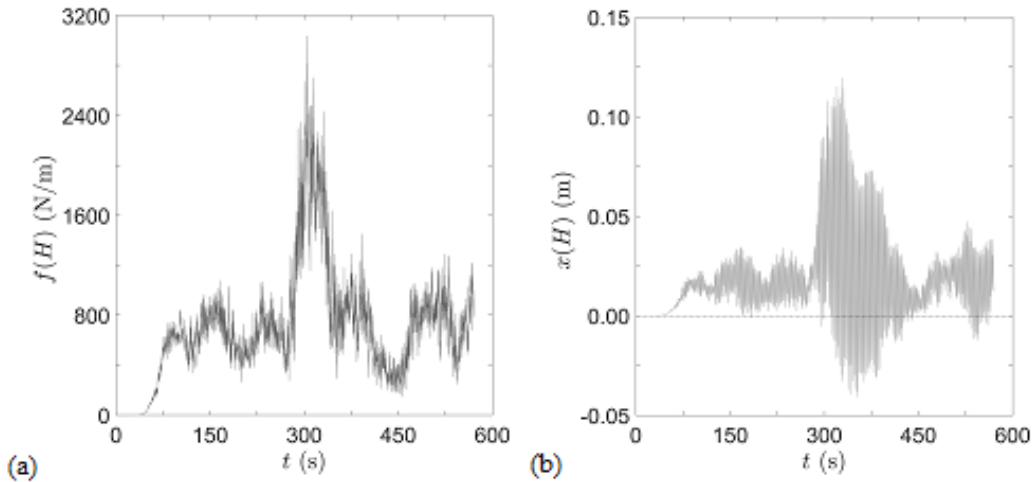

Figure 11: Force (a) and displacement (b) at the top of Structure 3 for a simulated thunderstorm outflow ($z_m = 100m$)

social impact and a renewed construction conception. Author maintains this is just the moment to use past experience, new tools and visionary ideas to draw a novel viewpoint that radiating from wind engineering propagates over civil engineering and impacts on society. It's time to change!

7 Acknowledgements

This study was funded by “Compagnia di San Paolo” for the Project “Wind monitoring, simulation and forecasting for the smart management and safety of port, urban and territorial systems” (grant number 2015.0333, ID ROL: 9820) and by Italian Ministry

of Instruction and Scientific Research (PRIN 2015) for the Project “Identification and diagnostic of complex structural systems” (grant number 2015TTJN95). The data exploited has been recorded by the monitoring network of the European Projects “Winds and Ports” and “Wind, Ports and Sea”, financed by the European Territorial Cooperation Objective, Cross-border program Italy-France Maritime 2007-2013.

References

- [1] C.W. Letchford, C. Mans, M.T. Chay, Thunderstorms – their importance in wind engineering (a case for the next generation wind tunnel), *Journal of Wind Engineering and Industrial Aerodynamics*, 90, pages 1415-1433, 2002.
- [2] G. Solari, Emerging issues and new frameworks for wind loading on structures in mixed climates. *Wind and Structures*, 19, pages 295-320, 2014.
- [3] A.G. Davenport, The application of statistical concepts to the wind loading of structures. *Proceedings of the Institution of Civil Engineers*, 19, pages 449-472, 1961.
- [4] G. Solari, M.P. Repetto, M. Burlando, P. De Gaetano, M. Pizzo, M. Tizzi, M. Parodi, The wind forecast for safety and management of port areas, *Journal of Wind Engineering and Industrial Aerodynamics*, 104-106, pages 266-277, 2012.
- [5] M.P. Repetto, M. Burlando, G. Solari, P. De Gaetano, M. Pizzo, M. Tizzi, A GIS-based platform for the risk assessment of structures and infrastructures exposed to wind, *Advances in Engineering Software*, in press, 2017.
- [6] M.P. Repetto, M. Burlando, G. Solari, P. De Gaetano, M. Pizzo, Integrated tools for improving the resilience of seaports under extreme wind events, *Journal of Sustainable Cities and Society*, in press, 2017.
- [7] P. De Gaetano, M.P. Repetto, T. Repetto, G. Solari, Separation and classification of extreme wind events from anemometric records, *Journal of Wind Engineering and Industrial Aerodynamics*, 126, pages 132-143, 2014.
- [8] G. Solari, M. Burlando, P. De Gaetano, M.P. Repetto, Characteristics of thunderstorms relevant to the wind loading of structures, *Wind and Structures*, 20, pages 763-791, 2015.
- [9] M. Burlando, A. De Cio, M. Pizzo, G. Solari, Analysis of wind vertical profiles of thunderstorm events in the Mediterranean, *Proceedings of the 9th Asia-Pacific Conference on Wind Engineering*, Auckland, New Zealand, submitted, 2017.
- [10] M. Burlando, D. Romanic, G. Solari, H. Hangan, S. Zhang, Field data analysis and weather scenario of a downburst event in Livorno, Italy 1 October 2012. *Monthly Weather Review*, re-review, 2017.

- [11] S. Zhang, M.P. Repetto, G. Solari, Q. Yang, Statistical analysis of extreme wind speed due to thunderstorm outflows, *Proceedings of the 7th European-African Conference on Wind Engineering*, Liege, Belgium, 2017.
- [12] G. Solari, P. De Gaetano, M.P. Repetto, Thunderstorm response spectrum: fundamentals and case study, *Journal of Wind Engineering and Industrial Aerodynamics*, 143, pages 62-77, 2015.
- [13] G. Solari, Thunderstorm response spectrum technique: theory and applications, *Engineering Structures*, 108, pages 28-46, 2016.
- [14] G. Solari, D. Rainisio, P. De Gaetano, Hybrid simulation of thunderstorm outflows and wind-excited response of structures. *Meccanica*, submitted, 2017.

Evaluation of spatial soil variability in the Pearl River Estuary using CPTU data

Emanuel Bombasaro¹

1: *Bedeschi Handling S.P.A., Italy, emanuel.bombasaro@bedeschi-handling.com*

Abstract. The design and particular the prediction of structure settlement behavior requires a detailed understanding of the sub soil characteristics [1]. As well known, the spatial stochastic properties of the soil can be described with the help of Random Fields [2].

In this contribution the process of deriving the spatial stochastic properties (i.e. mean, variance, vertical and horizontal scales of fluctuation) from cone penetration tests with pore pressure measurement (CPTU) [3] is presented. The initial idea are given in [1], [2], [3], [4] and [5] where the spatial stochastic properties are derived for the whole soil body, disregarding the different soil layers, [4]. In contrast in this contribution the spatial stochastic properties are derived for individual soil layers, [6].

The approach was applied to data obtained from a project in the Pearl River Estuary. The very extensive site characterisation stretches over 6.762 m length and 50 m width covering an area of 338.100 m² with CPTU soundings every 25 m. The stratigraphy is derived from bore holes in combination with the CPTU soundings. Soil types found in the Pearl River Estuary are: marine clay and sand, continental clay, marine alluvial clay and sand, fluvial alluvial clay and sand.

References

- [1] E.H. Vanmarcke. Probabilistic modeling of soil profiles, *J.Geotech. Eng. Div.*, volume 103, issue 11, pages 1227-1246, November 1977.
- [2] E.H. Vanmarcke, *Random Fields: Analysis and Synthesis*. MIT Press Classics, Singapore, 1983.
- [3] T. Lunne, J. Powell, P. Robertson, *Cone Penetration Testing in Geotechnical Practice*. Taylor and Francis Group, London, 1997.
- [4] G.A. Fenton. Estimation for stochastic soil models, *Geoenviron. Eng.*, volume 125, issue 6, pages 470-485, June 1999.
- [5] G.B. Baecher, J.T. Christian, *Reliability and Statistics in Geotechnical Engineering*. John Wiley & Sons Ltd, West Sussex, 2003.

- [6] E. Bombasaro, T. Kasper. Evaluation of spatial soil variability in the Pearl River Estuary using CPTU data, *Soils and Foundations*, volume 56, issue 3, pages 496-505, June 2016.

Evaluation of steel buildings by means of non-destructive testing methods

Christian Fox¹, Markus Doktor², Wolfgang Kurz¹

1: University of Kaiserslautern, Department of Civil Engineering, christian.fox@bauing.uni-kl.de

2: University of Kaiserslautern, Department of Mathematics, doktor@mathematik.uni-kl.de

Abstract. Non-destructive testing methods became popular within the last few years. For steel beams shored in buildings there are currently only destructive ways for testing the yield limit as well as for determination of the current stress level. Rise of ultrasonic and micro-magnetic tools for (non-destructive) measurements allows the characterization of the inbuild material especially old steel bridges as economical and economical menance of the infrastructure.

Inbuild steel beams are inhomogeneous, under stress and have typically unhandable surfaces leading to measurements affected with errors. Our solution was the use of adapted statistical tests, a median-based outlier-test, to get a valid dataset. A further step, using non-causal time series, has been made to reduce in-data dependencies, probably caused by the measuring devices or the production process. The estimation of the stress curve was done with a cubic spline based regression approach which has shown an unexpected behaviour of the residuals. Further test has shown that there are again dependencies between different points of measurements. A non-causal time series approach solved that problem and further led to Monte-Carlo based confidence bands which has to be adapted to the valid standard.

Combining ultrasonic and micromagnetic data, gaining new dependency structures, an increase of the quality of the estimation is observed. This is used to estimate all internal forces of the steel beam in face of depended data. Bad numerical condition of the numerical procedures caused by dependencies inhibited that in the simple case without combination which is technically challenging in practice.

Proving the load carrying capacity of buildings according to valid standards will then be possible, more precise and much cheaper than the current state-of-the-art.

References

- [1] M. Doktor, C. Fox, W. Kurz, et al. *FOSTA Bericht P859 Bestandsbewertung von Stahlbauwerken mithilfe zerstörungsfreier Prüfverfahren*
- [2] C. Fox, M. Doktor, W. Kurz, E. Schneider. Beitrag zur Bewertung von Stahlbauwerken durch zerstörungsfreie Prüfung von Spannungszuständen, *STAHLBAU*, volume 85, pp. 1-15, 2016.

Higher order Riesz-transform in the context of multi-resolution orientation estimation

Martin Reinhardt¹, Swanhild Bernstein², Bettina Heise³

1: *Freiberg University of Mining and Technology, Institute of Applied Analysis, martin.reinhardt@math.tu-freiberg.de*

2: *Freiberg University of Mining and Technology, Institute of Applied Analysis*

3: *CDL MS-MACH, FLLL, ZONA, Johannes Kepler University, Linz, Austria*

Abstract. We discuss the combination of the TKEO tensor with Riesz transform and a monogenic multi-resolution analysis in comparison to conventional gradient and Riesz transform-based approaches. We show that benefits of approaches, the stability of mixed (higher) order of derivatives, like given in TKEO operator, the all-pass filter characteristics featuring the Riesz transform and the scale-based analysis can be maintained in the combination. Furthermore, we demonstrate the ability of considered technique for extracting structural defects at different scales, estimating orientation or being used for 2D demodulation of amplitude-and phase modulated signals, like interferometric fringe patterns.

From the viewpoint of mathematical analysis we will emphasise the connection to hyper-complex signals, Clifford frames and monogenic multi-resolution signal analysis. Further, we will discuss higher order Riesz transform and its fractional realizations, which may also find analogies in optical filter design.

Optimal experimental design for parameter identification in a geotechnical application

Raoul Hölder¹, Elham Mahmoudi², Markus König², Tom Schanz²

1: Ruhr-Universität Bochum, Dep. of Civil and Environmental Engineering, raoul.hoelter@rub.de

2: Ruhr-Universität Bochum, Dep. of Civil and Environmental Engineering

Abstract. The present work employs the Monte-Carlo based Bootstrap approach for the purpose of “Optimal Experimental Design” (OED) to conduct a parameter identification. Parameter identification based on observed values is a well established practice in geotechnical engineering, known as observational method [1]. Employing an OED-approach shall improve the observational method and allow more precise results. The methodology is illustrated with the numerical simulation of a synthetic dike example that is subjected to a fast drawdown of the water level. Variables of the experimental design are the position and number of the sensors for pore water pressure u_w , and vertical and horizontal displacements u_y and u_x , respectively. In a first step, global sensitivity analysis is employed to identify the most relevant constitutive parameters as well as the areas in which measurements are most promising to identify them. By creating noisy, synthetic outputs that are related to each of the possible sensors, resampling is performed. An inverse analysis of the soil’s constitutive parameters is applied to these outputs using different measurement designs. The variance of the identified results allows a statement on the quality of these numerous arrangements. Different scenarios are considered to identify an optimal design. First, a fixed amount of three sensors for both measurement types is employed, and second, the number of sensors is varied from 1 to 3 each. In each case, the suggested positions are comprehensible and agree with a former work on this field, with application to a geotechnical testing device [2]. The significant advantage of using the bootstrap method is that it does not only indicates in which area it is worthwhile to put more sensors, but that the interaction of each types of sensors is considered as well. In this way it is possible to precisely define the number of different sensor types and their impact on the accuracy of a subsequent parameter identification.

References

- [1] R.B. Peck. Advantages and limitations of the observational method in applied soil mechanics, *Geotechnique*, 19(2), 1969.
- [2] R. Hölder, E. Mahmoudi and T. Schanz. Optimal sensor location for parameter identification in soft clay. In Proceedings of IAIP’15: *7th International Conference for Promoting the Application of Mathematics in Technical and Natural Sciences*, <http://dx.doi.org/10.1063/1.4934289>, 2015.

GRK 1462 - Reference project “Poles”: monitoring system, lab experiments and long-term measurements

**Lars Abrahamczyk¹, Feras Alkam², Hisham Al Hanoun¹, Luise Göbel¹,
Zouhour Jaouadi¹, Matthias Kraus³, Igor Kavrakov¹, Dmitrii Legatiuk⁴,
Felix Mucha¹, Sebastian Rau¹**

1: *Bauhaus-Universität Weimar, GRK 1462*

2: *Bauhaus-Universität Weimar, ISM*

3: *Bauhaus-Universität Weimar, Chair of Steel and Hybrid Constructions*

4: *Bauhaus-Universität Weimar, Chair of Applied Mathematics*

Abstract. Structures within the field of civil engineering of civil engineering are mostly unique. Because of this, investigations of such systems are normally only partially possible and their results are not applicable to other civil engineering structures. Pre-stressed spun-cast concrete poles, which are located next to railway tracks of the Deutsche Bahn, are numerous available. With the possibility of repeating measurements on many identically produced structures, statistical properties of the dynamic behaviour can be determined.

For this aim, structural monitoring is conducted that includes measurements of the structural behaviour from the production process to long-term loading conditions. The determination of real material parameters and external actions as well as the determination of associated structural responses are within the goal of this study. Furthermore, quantification of seasonal influences on the structural behaviour and aspects about soil-structure-interaction are investigated.

The monitoring of the poles is divided into two parts. Short-term measurements are conducted for determination of system characteristics like mode shapes and natural frequencies. During long-term monitoring, three poles, which are located directly next to each other, are observed.

For experimental tests in the laboratory, four concrete poles were investigated with particular focus on the determination of material properties and of the dynamic behaviour.

Finally, coupling between results of the monitoring, experimental investigations and of the numerical analyses are used to increase the prediction quality of models used in structural engineering.

GRK 1462 - Reference object “Telecommunication Tower”: Structural monitoring for model validation

**Volkmar Zabel¹, Simon Marwitz¹, Kosmas Dragos², Maria Steiner²,
Sharmistha Chowdhury², Ina Reichert², Tajammal Abbas³**

1: *Bauhaus-Universität Weimar, Institute of Structural Mechanics*

2: *Bauhaus-Universität Weimar, GRK 1462*

3: *Bauhaus-Universität Weimar, Modelling and Simulation of Structures*

Abstract. Mostly, the resistance and serviceability of civil engineering structures is proven by means of numerical models. This does not only apply to new structures but also to existing systems that have to be considered either within a regular inspection and maintenance plan for life-cycle assessment or in the context with rehabilitation measures. However, as the quality of numerical models strongly depends on assumptions about several parameters, numerous uncertainties exist.

One possibility to reduce the uncertainties in models of existing systems is a validation using experimental results. If the system’s performance has to be assessed under different environmental and loading conditions, the most appropriate experimental approach is to monitor the respective system over a long period.

The system considered in this study is a telecommunication tower. Even though the structural system which is a cantilever may appear to be relatively simple, several challenges are connected with this structure. As the circular cross-section of the tower is rotational symmetric, it should theoretically have pairwise orthogonal mode shapes in arbitrary directions at identical frequencies. Accordingly, one of the addressed questions in this study was the relation between modal parameters and environmental conditions. The second objective was the identification of the efficiency of a tuned mass damper (TMD) installed on the tower. As the TMD is hardly accessible, conventional methods based on the comparison between the blocked and released states could not be applied in this case. Consequently, a new procedure that entirely uses monitored response data was developed and applied. The third focus was the validation of a numerical approach that couples the simulation of the global structural response due to a stochastic wind excitation with a local stress analysis.

Based on these objectives, a monitoring concept was developed and transferred to its practical application to an approximately 200 m tall tower. The investigations covered the complete technical implementation, the data analyses including the considerations of uncertainties related to data processing and eventually the coupling of experimental results with numerical models. By means of the analyses, several conclusions with respect to the structural behaviour and the performance of the system under different conditions could be drawn.

Embedding models into wireless sensor nodes for decentralized structural health monitoring

Kosmas Dragos¹, Kay Smarsly²

1: *Bauhaus-Universität Weimar, GRK 1462, kosmas.dragos@uni-weimar.de*

2: *Bauhaus-Universität Weimar, Chair of Computing in Civil Engineering*

Abstract. An integral part of Industry 4.0-based applications in civil engineering are smart sensor systems that are used within structural health monitoring (SHM) systems to monitor and to analyze the condition of engineering structures. In recent years, wireless sensing technologies have been increasingly adopted in structural health monitoring. The financial merits of eliminating the need for long cables as well as their ease of installation have rendered wireless sensor nodes an attractive alternative for SHM as compared with cable-based sensors. Moreover, wireless sensor nodes are essentially integrated processing platforms capable of autonomously executing computational tasks. The processing capabilities of wireless sensor nodes have fueled research in embedding algorithms into the sensor nodes to perform monitoring tasks directly on board, thus enabling the decentralization of SHM systems. Transmitting only the useful information from the SHM outcome rather than long streams of raw structural response data for offline analysis enhances the power efficiency of wireless SHM systems. Over the years, several approaches on embedding models, i.e. algorithms that perform monitoring tasks, in wireless sensor nodes have been proposed. Typically, embedded models focus on identifying the structural state, in terms of structural properties, such as dynamic behavior parameters, and on predicting the structural behavior. In this paper, some of the most commonly used embedded models for structural health monitoring are presented, while their efficiency in monitoring is discussed. The paper concludes with a suggested framework on assessing the performance of embedded models.

Model-based force identification and response estimation in structural dynamics

Geert Lombaert¹, Kristof Maes¹

1: *KU Leuven, Department of Civil Engineering, Leuven, Belgium*

Abstract. The knowledge of dynamic loads acting on structures and the corresponding system response, referred to as the system state, is very important for many engineering applications. In various cases, however, these forces cannot be directly measured. Similarly, the response of a structure cannot be measured at all physical locations due to practical and economical considerations. System inversion techniques allow combining available vibration data from a limited number of sensors with the information obtained from a dynamic model of the structure, hereby estimating the forces acting to the structure and the response at unmeasured locations. Filtering techniques allow for online system inversion and as such for real time monitoring of structures.

This contribution presents two applications of filtering techniques in structural dynamics. The first case shows the application of a state of the art joint input-state estimation algorithm for force identification on a footbridge. The second case shows the application of the same joint input-state estimation algorithm and a classical Kalman filter algorithm for strain estimation in the tower of an offshore monopile wind turbine. In both cases, real measured data obtained from in situ measurements are used for the estimation. The quality of the force and response estimates is assessed by comparison with the corresponding measured quantities.

Elastic properties of polymer-modified concrete derived from experimental and computational multiscale approaches

Luise Göbel¹, Andrea Osburg²

1: *Bauhaus-Universität Weimar, GRK 1462, luise.goebel@uni-weimar.de*

2: *Bauhaus-Universität Weimar, F.A. Finger-Institute of Building Engineering Materials*

Abstract. Polymer-modified mortars and concretes (PCC) have been used in repair and restoration applications frequently. The polymer modification, more specifically the synergy between the cementitious and the polymer components, provokes improved properties such as durability, adhesive strength and impermeability. Recently, the application of PCC in construction purposes has grown which requires advanced modeling and simulation techniques for the prediction of the mechanical material behavior. The development of models for PCC helps to establish recommendations in design standards. Multiscale model considering microstructural characteristics are promising for the prediction of the mechanical behavior of PCC. For the development of multiscale models, a substantiated understanding of the microstructure is fundamental.

The present study is devoted to a comprehensive experimental analysis of the micromechanical properties of polymer-modified cement pastes by means of the nanoindentation technique. The grid nanoindentation and statistical deconvolution methods were employed. The elaborated database motivates its exploitation in form of multiscale models based on continuum micromechanics. For that, existing multiscale methods for the homogenization of the elastic stiffness were extended. The modeling results were validated with experimental data derived from macroscopic mechanical tests on polymer-modified cement pastes, mortars and concretes.

Multiscale models: from nano-scale to large-scale structures

Amin Tanhadoust¹

1: *Isfahan University of Technology, Civil Engineering Department, Isfahan, Iran*

Abstract. In physics, chemistry and mechanics, multiscale modeling is aimed to calculation of material properties or system behavior on one level using information or models from different levels. On each level particular approaches are used for description of a system. The level of quantum mechanical models, level of molecular dynamics models, coarse-grained models, mesoscale or Nano level, level of continuum models, level of device models are usually distinguished.

Multiscale modeling generally not only refers to length scale, but also consider the time scale and disciplinary of governing equations. Multiscale materials modeling combines existing and emerging methods from diverse scientific disciplines to bridge the wide range of time and length scales that are inherent in a number of essential phenomena and processes in materials science and engineering.

By considering simultaneously models at different scales, we hope to arrive at an approach that shares the efficiency of the coarse-scale models as well as the accuracy of the fine-scale models (or other scales).

Multiscale methods can be divided into two classes:

Hierarchical Multiscale: Hierarchical (sequential) method which determines several key variables of the upper scale based on a lower-scale simulation using appropriate methods that obey physical laws. Hierarchical models are those in which the constitutive response at fine-scales is used as input to boundary value problems at larger scales. The input typically takes the form of an initial condition, constitutive parameter or boundary condition. Hierarchical models have been successful for certain reasons. One is their ability to embed material length scales into the homogenized model; this can, for instance, provide regularization in the numerical implementation. More generally, hierarchical models offer a natural way of incorporating small-scale material physics into large-scale constitutive behavior such that constitutive coupling occurs between the length scales.

Concurrent Multiscale: Concurrent multiscale methods are those that run simultaneously; in these methods, the information at the smaller scale is calculated and inputted into the larger scale model on the fly. The concurrent approach performs calculations simultaneously to consider strong coupling among scales. It is suitable for cases where a strong coupling exists between different scales, such as turbulence and elastoplastic crack propagation in a finite medium. The key issue is then the coupling

between the coarse and fine scales. Typically, concurrent coupling involves the idea of a transient region.

There are a lot of works based on multiscale methods. For example in nanoscale, Molecular Dynamics and continuum finite element for Nano and microscales, Crack Propagation, dislocations, impurity, MEMS and NEMS, etc. in Nano and macroscale.

Especially in Civil and Structural Engineering there are numerous cases that multiscale simulation is useful. The cases that contain elements with various length scale or governing equations. Structures with new generation materials (such as dampers), elevated water tanks, materials with super elastic behavior, mechanical instrumentation and various loadings. Another Example is the planning of large infrastructure projects, such as tunneled inner-city carriageways, completely different scales have to be considered, ranging from the scale of several kilometers for the general routing of the carriageway down to centimeter scale for the detailed planning of track nodes.

The advantages of multiscale methods are indispensable, but there are many challenges, from linking scales and transient zone to asymmetric stiffness matrix problem, ill condition of matrices and scale of time steps.

Conceptual modelling methodology for assessment of coupling of models

Dmitrii Legatiuk¹

1: *Bauhaus-Universität Weimar, Chair of Applied Mathematics, dmitrii.legatiuk@uni-weimar.de*

Abstract. Typical problems in engineering nowadays are coupled problems requiring consideration not a single model, but rather a coupled combination of different models. Inappropriate treatment of a coupling between the models could lead to wrong results, and therefore it is necessary to have tools for the assessment of the coupling between different models. The requirement for such a tool is its applicability to different problems and different fields of engineering. This request can be satisfied by working with conceptual modelling methodologies allowing a general description of the modelling process. Such a conceptual modelling methodology based on category theory will be presented in the talk.

References

- [1] K. Gürlebeck, D. Hofmann, D. Legatiuk. Categorical approach to modelling and to coupling of models, *Mathematical Methods in the Applied Sciences*, 2016, DOI: 10.1002/mma.3978.
- [2] D. Legatiuk, K. Dragos, K. Smarsly. Modeling and evaluation of cyber-physical systems in civil engineering, *Proceedings in Applied Mathematics and Mechanics*, 2017.
- [3] D. Legatiuk, M. Theiler, K. Dragos, K. Smarsly. A categorical approach towards metamodeling cyber-physical systems, *Proceedings of the 11th International Workshop on Structural Health Monitoring.*, 2017.

Aerodynamic modelling via categorical approach

Igor Kavrakov¹, Dmitrii Legatiuk², Klaus Gürlebeck², Guido Morgenthal³

1: *Bauhaus-Universität Weimar, Research Training Group 1462, igor.kavrakov@uni-weimar.de*

2: *Bauhaus-Universität Weimar, Chair of Applied Mathematics*

3: *Bauhaus-Universität Weimar, Chair of Modelling and Simulation of Structures*

Abstract. Wind induced vibrations commonly constitute a leading criterion in the design of long-span bridges. Traditionally, semi-analytical models aided with experimentally obtained coefficients have been used to model the wind forces acting on a bridge deck excited by gusty wind. In the last two decades, the Computational Fluid Dynamics (CFD) has proved to be a useful alternative for obtaining the aerodynamic coefficients such as static wind coefficients and flutter derivatives and seldom the aerodynamic response. The semi-analytical models are based on a different set of underlying assumptions in order to simplify the complex fluid structure interaction. Therefore, they neglect certain aerodynamic phenomena such as the nonlinear behavior of the aerodynamic forces with respect to the angle of incidence, the fluid memory resulting from the time lag between the motion of the fluid and dynamic wind coefficients and the aerodynamic coupling. As a CFD model, the Lagrangian Vortex Particle Method (VPM) is utilized. Extended with the recently developed method for 2D synthetic turbulent flow generation, the CFD model is used to obtain the aerodynamic coefficients and the turbulent wind response. In this work, a methodology to define the complexity of various semi-analytical aerodynamic models and a CFD model utilizing the category theory on a more abstract level is presented. With this, the influence of their assumptions on the aerodynamic response is studied. The displacements of a 2D streamlined bridge deck is taken as a quantity of interest for various wind velocities. Taking this into account, the propagation effects of the model assumptions are studied over a broad wind velocity range. The effect on the on-set flutter velocity is studied as well. The category theory provides a language which helps to describe properties of different objects using their representation with diagrams of arrows. Using the advantages of the category theory, the aerodynamic models are presented in a concise way, allowing one to easily distinguish the models with higher complexity and the phenomena they account for. Finally, the quantified discrepancies between the aerodynamic models are used to develop a better understanding of the aerodynamic behavior of a streamlined bridge deck.

References

- [1] K. Gürlebeck, D. Hofmann, D. Legatiuk. Categorical approach to modelling and to coupling of models, *Mathematical Methods in the Applied Sciences*, 2016, DOI: 10.1002/mma.3978.

- [2] D. Legatiuk, K. Dragos, K. Smarsly. Modeling and evaluation of cyber-physical systems in civil engineering, *Proceedings in Applied Mathematics and Mechanics*, 2017.
- [3] D. Legatiuk, M. Theiler, K. Dragos, K. Smarsly. A categorical approach towards metamodeling cyber-physical systems, *Proceedings of the 11th International Workshop on Structural Health Monitoring.*, 2017.

Inverse and ill-posed problems in coupled systems

Tom Lahmer¹, Long Nguyen-Tuan², Muiyiwa Alalade², Bac Nam Vuc²

1: *Bauhaus-Universität Weimar, Institute of Structural Mechanics, tom.lahmer@uni-weimar.de*

2: *Bauhaus-Universität Weimar, Institute of Structural Mechanics*

Abstract. Many structures and systems in engineering are characterized by interactions between different fields and quantities. Therefore, multifield descriptions gain more and more importance, where examples are to be found in fluid-structure interaction problems, thermo-mechanical or piezoelectrical problems, electro-magneto-mechanical interactions in electric mobility and so on, see, e.g. [1,2]. These problems occur frequently in different disciplines like civil engineering, environmental engineering, geotechnical engineering and virtual material development. Most of the physical phenomena in the different field can be well described by means of systems of coupled partial differential equations. Depending on the type of analysis they appear either as static or time dependent problems. One of the challenges, besides an effective numerical approximation, is the determination of components of the models like material parameters, source terms and boundary conditions. This determination from given experimental data is handled by solving so called inverse problems.

The talk will introduce some typical inverse problems for coupled problems and will highlight the challenges while solving them [3-5].

References

- [1] Nguyen-Tuan, C. Könke, V. Bettzieche, T. Lahmer, Numerical modeling and validation for 3D coupled-nonlinear thermo-hydro-mechanical problems in masonry dams, *Computers and Structures*, Volume 178, January 2017, Pages 143–154.
- [2] T. Lahmer, E. Rafajlowicz, On the Optimality of Harmonic Excitation As Input Signals for the Characterization of Parameters in Coupled Piezoelectric and Poroelastic Problems, *Mechanical Systems and Signal Processing*, Vol 80, 2017.
- [3] T. Lahmer, S. Bock, J. Hildebrand, K. Gürlebeck, Non-destructive Identification of Residual Stresses in Steel under Thermal Loadings, *Journal of Inverse Problems in Science and Engineering*, 2017.
- [4] M. Alalade, L. Nguyen-Tuan, F. Wuttke & T. Lahmer, Damage identification in gravity dams using dynamic coupled hydro-mechanical XFEM, *International Journal of Mechanics and Materials in Design*, 2017, 1-19 .
- [5] S. S. Nanthakumar, C. Zhang, T. Lahmer, T. Rabczuk, Multiple cracks identification for piezoelectric structures, *International Journal of Fracture*, 2017

Surrogate models for real-time predictions in mechanized tunneling

Steffen Freitag¹, Ba Trung Cao², Günther Meschke²

1: Ruhr University Bochum, Institute for Structural Mechanics, steffen.freitag@sd.rub.de

2: Ruhr University Bochum, Institute for Structural Mechanics

Abstract. Real-time simulations allow to steer and control construction processes based on predictions. Here, a real-time simulation concept for mechanized tunneling processes is presented, which is applied to reduce tunneling induced settlements.

The machine driver can adjust the process parameters such as the face support pressure, the grouting pressure, and the advance speed of the tunnel boring machine (TBM) to avoid that accepted settlements are exceeded, which eventually may result in damage of existing structures.

In contrast to monitoring based systems, where information (data) related to already passed situations is used to extrapolate the tunneling process, simulation based numerical predictions include the physical behavior of the underlying structural processes.

First, a process oriented 3D finite element (FE) model [1] for shield-supported tunnel excavation is utilized taking into account all relevant components of a mechanized tunneling process, i.e. the repeated sequence of soil excavation, the advancement of the TBM and the installation of the lining segments.

For real-time predictions during the tunnel construction, the FE model is substituted by a hybrid surrogate model [2] combining Artificial Neural Network and Proper Orthogonal Decomposition approaches.

The surrogate model parts are generated, trained and tested in the design (offline) stage of a tunnel project using input-output patterns obtained from the FE analyses.

In the construction (online) stage, the hybrid surrogate model is applied to compute the time variant surface settlement field according to the selected steering parameters taking uncertain geotechnical parameters by means of intervals into account.

This prediction is solved online by an interval analyses approach using the midpoint-radius representation [3]. The computational time of the new surrogate modeling approach is only about 2 seconds to compute the interval bounds of a settlement field with more than 100 settlement components.

References

- [1] A. Alsahly, J. Stascheit, and G. Meschke. Advanced finite element modeling of excavation and advancement processes in mechanized tunneling, *Advances in Engineering Software*, 100, 2016, pp. 198–214, DOI: 10.1016/j.advengsoft.2016.07.011

- [2] B.T. Cao, S. Freitag, and G. Meschke. A hybrid RNN-GPOD surrogate model for real-time settlement predictions in mechanised tunnelling, *Advanced Modeling and Simulation in Engineering Sciences*, 3 (5), 2016, DOI: 10.1186/s40323-016-0057-9
- [3] S. Freitag, B.T. Cao, J. Ninic, and G. Meschke. Recurrent neural networks and proper orthogonal decomposition with interval data for real-time predictions of mechanised tunnelling processes, *Computers and Structures*, 2017, in press, DOI: 10.1016/j.compstruc.2017.03.020

Investigation of a global adaptive sampling method based on Least-square support vector regression

Maria Steiner¹, Tom Lahmer², Jean-Marc Bourinet³

1: Bauhaus-Universität Weimar, Research Training Group 1462, maria.steiner@uni-weimar.de

2: Bauhaus-Universität Weimar, Institute of Structural Mechanics, tom.lahmer@uni-weimar.de

3: SIGMA Clermont, bourinet@sigma-clermont.fr

Abstract. In many engineering fields, a global sensitivity analysis of the model seems to be advantageous since it provides a basis to judge on the importance of the parameters; nevertheless, the sensitivity analysis needs numerous data points and correspondingly, considerable computational cost. A common technique to overcome this problem is to use the so-called metamodels with which the required data can be reduced by using some points to construct the metamodel and approximate the remaining points. However, often more sample points have to be added if the required quality of the approximation is not reached. In this contribution a novel global adaptive sampling method based on the least-squares support vector regression is presented.

1 Introduction

Numerous application fields in civil engineering, such as reliability analysis, sensitivity analysis, and nonlinear optimization, require large amounts of simulation data. For approximation of this data and thereby reducing the calculation time, metamodels are commonly applied. There are various papers about different model choices and optimal sampling strategies (e.g. [1, 2]). To improve the approximation quality, adaptive sampling methods are used. However, most of the existing methods focus on specific areas (e.g. [3, 4]) and cannot be applied to global sensitivity analysis. Therefore, in this contribution, we introduce a novel global adaptive sampling method.

The paper is structured as follows: First, the theory of the least-squares support vector regression is explained. Then we introduce the novel adaptive sampling method and, finally, apply this method to two different numerical examples, thus showcasing the efficiency of the proposed method.

2 Theory of the least-squares support vector regression

In this section the least-squares support vector regression (LS-SVR), employed in this paper, is explained. We shortly introduce the basic concept for all types of metamodels,

and then we discuss the linear and the nonlinear case of the LS-SVR. At the end of this section we focus on the benefits of this method, which makes it useful to apply to an adaptive sampling method.

When using a metamodel, a set of support data points $\mathbf{x}_1, \dots, \mathbf{x}_n \in \mathbb{R}^k$ with known responses $\mathbf{y} = [y_1, \dots, y_n]^T = [f(\mathbf{x}_1), \dots, f(\mathbf{x}_n)]^T$ of a black box function f , either a physical or a computer experiment, is required. Because the function f is often hard to evaluate, it is of advantage to approximate the behavior with a metamodel \hat{f} in order to reduce the number of necessary function calls. Accordingly, the number n of support points should be chosen low; although, in most cases, the approximation quality increases with higher n . For all metamodels there are different concepts on how to produce the approximation function with the given support data set. One class of algorithms are the support vector regression (SVR) methods, which have been originally introduced in the context of binary classification [5, 6] and then extended to regression methods [7].

A special form of the SVR methods is the LS-SVR [8, 9]. In a linear case we are approximating with

$$\hat{f}(\mathbf{x}) = \mathbf{w}^T \mathbf{x} + b, \quad (1)$$

where the model parameter $\mathbf{w} = [w_1, \dots, w_k]^T$ and b have to be defined. The optimization problem to solve is as follows:

$$\begin{aligned} \min_{\mathbf{w}, b, \zeta} \quad & \frac{\|\mathbf{w}\|^2}{2} + \frac{C}{2} \sum_{i=1}^n \zeta_i^2, \\ \text{s.t.} \quad & y_i = \mathbf{w}^T \mathbf{x}_i + b + \zeta_i, \quad i = 1, \dots, n. \end{aligned} \quad (2)$$

In contrast to the classical SVR methods, we minimize the sum of squares of the errors $\zeta_i = y_i - \hat{f}(\mathbf{x}_i)$ penalized by $C > 0$. By applying the Lagrangian function and the Karush-Kuhn-Tucker conditions for optimality, we obtain the following dual optimization problem:

$$\begin{bmatrix} \mathbf{K} + C^{-1} \mathbf{I}_{n \times n} & \mathbf{1}_n \\ \mathbf{1}^T & 0 \end{bmatrix} \begin{pmatrix} \boldsymbol{\alpha} \\ b \end{pmatrix} = \begin{pmatrix} \mathbf{y} \\ 0 \end{pmatrix} \quad (3)$$

with $(\mathbf{K})_{ij} = \mathbf{x}_i^T \mathbf{x}_j$ and the n Lagrangian multipliers $\boldsymbol{\alpha} = [\alpha_1, \dots, \alpha_n]^T$. It should be noted that the LS-SVR formulation requires solving a linear set of equations instead of solving a convex quadratic optimization problem appearing in most SVR concepts. Therefore, less computational effort is required to obtain the approximation function, expressed as

$$\hat{f}(\mathbf{x}) = \sum_{i=1}^n \alpha_i \mathbf{x}_i^T \mathbf{x} + b. \quad (4)$$

Though, the prediction is written in terms of all support points and thereby cannot be formulated with sparse matrices, which is often considered as a disadvantage with regards to the classical SVRs if n becomes large. Anyway, we want to keep n low, since n is the number of the expensive functions calls of the original function f .

The extension to the nonlinear case is achieved using kernel functions. The main idea of this extension is to map the input points into a nonlinear feature space to enable the construction of a linear model in this space. Formulating the kernel function k is sufficient, rather than explicitly defining the mapping. The resulting approximation function is expressed as

$$\hat{f}(\mathbf{x}) = \sum_{i=1}^n \alpha_i k(\mathbf{x}_i, \mathbf{x}) + b. \quad (5)$$

The optimal parameters $\boldsymbol{\alpha}$ and b can be obtained in the same way as in the linear case solving optimization problem Equation 3, where $(\mathbf{K})_{ij}$ is now defined with kernel function $k(\mathbf{x}_i, \mathbf{x}_j)$. There are different possible kernel functions [10, 11] and the kernel function we use in this contribution is the Gaussian kernel:

$$k(\mathbf{x}_i, \mathbf{x}_j) = \exp\left(-\frac{\|\mathbf{x}_i - \mathbf{x}_j\|^2}{2\sigma^2}\right) \quad (6)$$

with $\sigma \in \mathbb{R}$.

To obtain the best approximation function, while avoiding both overfitting and underfitting, we need to find the most suitable kernel parameter σ and the optimal regularization parameter C . One frequently applied selection criterion is the cross-validation error, where the support data set is split into sub data sets and each time one is left out to have untrained testing points. A special case is the leave-one-out cross-validation, where \hat{f}^{-i} is the metamodel constructed without the use of the i '-th support point. The response of this metamodel is compared with the true function value y_i , so that the leave-one-out error Err_{LOO} is formulated as

$$Err_{\text{LOO}} = \frac{1}{n} \sum_{i=1}^n (y_i - \hat{f}^{-i}(\mathbf{x}_i, C, \sigma))^2. \quad (7)$$

The parameters C and σ are chosen so as to minimize Err_{LOO} . Typically, this calculation needs a high computational effort because the metamodels \hat{f}^{-i} with $i = 1, \dots, n$ has to be constructed anew each time. However, the LS-SVR enables an analytical calculation of the loss between $y_i - \hat{f}^{-i}(\mathbf{x}_i)$ [12] through

$$y_i - \hat{f}^{-i}(\mathbf{x}_i) = \frac{\alpha_i}{(\tilde{\mathbf{K}}^{-1})_{ii}}, \quad (8)$$

where $(\tilde{\mathbf{K}}^{-1})_{ii}$ is the i -th diagonal element of the inverse of

$$\tilde{\mathbf{K}} = \begin{bmatrix} \mathbf{K} + C^{-1}\mathbf{I}_{n \times n} & \mathbf{1}_n \\ \mathbf{1}^T & 0 \end{bmatrix}. \quad (9)$$

This method needs low computational cost on the one hand due to the linear optimization problem and on the other hand due to the simple parameter estimation. Hence, the LS-SVR is especially useful for high dimensional problems and for the applied adaptive sampling method.

3 Global adaptive sampling method based on LS-SVR

An important question during the process of building an approximation function is, how to construct the support data set. There are different sampling methods, such as full factorial and stratified random sampling techniques [1]. A stratified random technique commonly used, is the Latin hypercube sampling (LHS). LHS is one of the most suitable methods for a space-filling sampling method without the use of prior knowledge on the structure of the model that has to be fitted. However, there is no conclusion about the optimal number of required support points and, if a satisfactory model quality is not reached, the support data set needs to be expanded with new points. Since this expansion cannot be done in the distribution of the LHS method, various adaptive sampling methods have been developed.

Depending on the application field, new points are added to the support data set for different objectives. In the field of nonlinear optimization and reliability analysis, local adaptive sampling strategies (e.g. [3, 4]) are used, since specific areas are of interest and need an improvement in the model quality. However, in this research, we focus on the application to global sensitivity analysis, which requires global adaptive sampling strategies.

It is important to identify areas where the metamodel has the lowest approximation quality and to improve the approximation by adding new points. The existing methods for improving the approximation quality are either restricted to the Kriging metamodel (e.g. the entropy approach [13]), time consuming (Cross-Validation Approach [14]), or do not take the information obtained from the existing metamodel into account (Maximin distance approach [15]). In what follows, we present a new global adaptive sampling method based on the LS-SVR, termed “distance-based LOO error method”.

In the distance-based LOO error sampling method two criteria are chosen to determine a new sampling point. First, we take the result of the leave-one-out error into account, as defined in Equation 7. This result is an indicator for the uncertainty in the approximation. For the LS-SVR, the analytical formulation of the contribution of each support point to the leave-one-out error is given in Equation 8. By using these values as support points and applying again the LS-SVR we construct a leave-one-out error function \hat{f}_{LOO} which shows areas with higher uncertainty. New sample points should be chosen where \hat{f}_{LOO} is maximal. Second, as in [14], the maximin distance approach is used for avoiding points close to already existing support points because no new information about the original function would be received. Therefore, new support points are selected from the optimization problem

$$\max_j (\hat{f}_{\text{LOO}}(\mathbf{x}_j^n) * \min_i d(\mathbf{x}_j^n, \mathbf{x}_i)), \quad (10)$$

where $d(\mathbf{x}_i, \mathbf{x}_j)$ is a distance function; in this research the Euclidean metric is selected. In the next section, we show the functionality of this sampling method by an example and demonstrate with a second example the advantages.

4 Numerical application

As a first example showcasing the functionality of the distance-based LOO error method, we observe the approximation of the one-dimensional function $f(x) = x \sin x$ within the interval $[0, 15]$. In Fig. 1, on the left hand side, the approximation with six support is plotted, while on the right hand side, \hat{f}_{LOO} is depicted. The new elected point regarding optimization problem from Expression 10 is marked with a cross in both plots. It is evident that the new point is chosen in an area where \hat{f}_{LOO} and the deviation of the approximation to the true function assume high values.

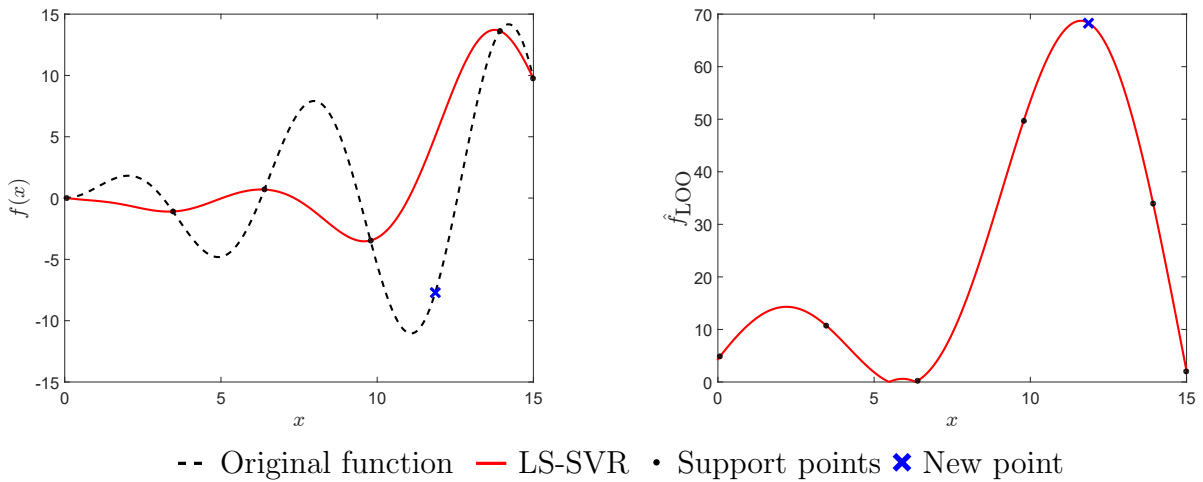

Figure 1: Choosing a new point with the distance-based LOO error method for $f(x) = x \sin x$, shown with the approximation function $\hat{f}(x)$ of $f(x)$ with six points and the related \hat{f}_{LOO}

To observe the efficiency of the introduced adaptive sampling method, we compare it with the LHS method considering the coefficient of determination based on an additional untrained validation data set (CoD_{val}) [11]. The CoD_{val} indicates a good approximation quality for values close to 1. Due to the additional validation data set, the CoD_{val} is on the one hand reliable, but, on the other hand, only useful for analytical examples. The boxplot of the CoD_{val} of each 100 approximations depending on $n = 5$ up to $n = 15$ is shown in Fig. 2. In the first case, labeled with “adaptive sampling method”, we started with 5 LHS points and added each step one point following the concept of the adaptive sampling method. For the second case, labeled with “LHS”, each time a new LHS support data set is constructed.

The results in Fig. 2 indicate no clear improvement by the use of the adaptive sampling method. However, the distance-based LOO error method improves the results in several cases, as shown in the next example.

As a second example, we observe the absolute value of the transfer function of the equation of motion described as follows:

- Equation of motion: $m\ddot{u}(t) + c\dot{u}(t) + ku(t) = 0$

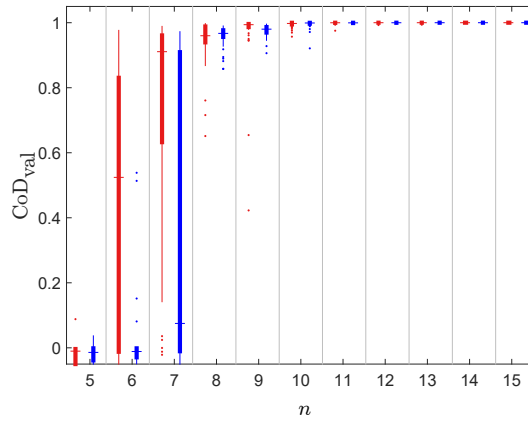

— Adaptive sampling method — LHS

Figure 2: Boxplot of the CoD_{val} for the distance-based LOO error method (left) and LHS method (right) depending on n for the approximation of $x \sin x$

Parameters: mass m , damping c , stiffness k ,
displacement $u(t)$, velocity $\dot{u}(t)$, acceleration $\ddot{u}(t)$ depending on the time t

- Transfer function: $H(\omega) = 1/(-m\omega^2 + c\omega i + k)$
- Observed function: $f(x) = |H(\omega)|$
- Parameters: $m = 1 \text{ kg}$, $c = 0.5 \frac{N \cdot s}{m}$, $k = 1 \frac{N}{m}$

This function is of interest because it behaves differently in different areas. In Fig. 3 we can see on the left hand side an approximation with the support points sampled using the adaptive sampling method and on the right hand side an approximation with LHS support points. It is obvious that the first approximation is closer to the true function, because more sample points are constructed where $f(x)$ is nonlinear.

By comparing the results of the CoD_{val} for 100 approximations for both the adaptive sampling method and the LHS method, it is also visible that the convergence to a acceptable solution is faster and more robust if the distance-based LOO error method is used, as illustrated in Fig. 4.

5 Conclusion and outlook

In this contribution, we introduced a new adaptive sampling method, which can be applied for the approximation of a costly function with the LS-SVR. The LHS method is commonly used to sample the support points for a metamodel. Although this sampling method distributes the points in a favorable way, it is not possible to add new points accordingly. By applying the introduced adaptive sampling method to add new points, the approximation quality increases and the results are more robust especially for functions with areas of high nonlinearity. Additionally, an adaptive sampling process gives the opportunity to stop the sampling process if a sufficient quality is reached.

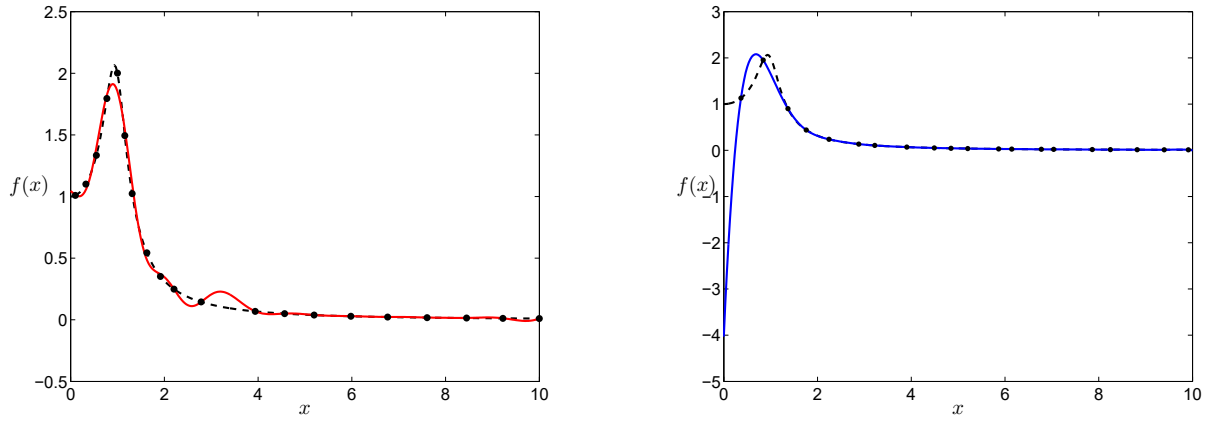

-- Original function — Adaptive sampling method — LHS

Figure 3: Approximation with the adaptive sampling method and the LHS method

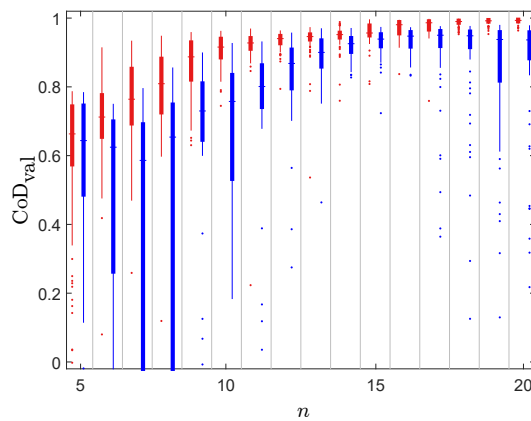

— Adaptive sampling method — LHS

Figure 4: Boxplot of the CoD_{val} for the distance-based LOO error method (left) and the LHS method (right) depending on n for the approximation of the absolute transfer function

Further research will show the functionality of the distance-based LOO error method in higher dimensions and discuss the question of the optimal starting point for the adaptive sampling method.

6 Acknowledgements

This research is supported by the German Research Foundation (DFG) via Research Training Group “Evaluation of Coupled Numerical Partial Models in Structural Engineering (GRK 1462)”, which is gratefully acknowledged.

References

- [1] A.I.J. Forrester, A. Sobester, and A. Keane, *Engineering design via surrogate modelling*, John Wiley and Sons, 2008.
- [2] T. Most, J. Will, Metamodel of Optimal Prognosis - an Automatic Approach for Variable Reduction and Optimal Metamodel Selection, *Tagesband der Weimarer Optimierungs- und Stochastiktag 5.0*, 2008.
- [3] D.R. Jones, M. Schonlau, and W.J. Welch, Efficient global optimization of expensive black-box functions, *Journal of Global Optimization*, 13 (4), pages 455–429, 1998.
- [4] V. Dubourg, B. Sudret, J.-M. Bourinet, Reliability-based design optimization using kriging surrogates and subset simulation, *Structural Multidisciplinary Optimization*, Springer-Verlag, 2011.
- [5] B.E. Boser, I.M. Guyon, and V.N. Vapnik, A training algorithm for optimal margin classifiers, In: *Proceedings 5th Annual Workshop on Computational Learning Theory (COLT'92)*, ACM Press, pages 144–152, Pittsburgh, PA, USA, 1992.
- [6] C. Cortes, V. Vapnik, *Support-vector networks*, *Machine Learning*, 20 (3), pages 273–297, 1995.
- [7] V. Vapnik, *The nature of statistical learning theory*, Springer-Verlag, 1995.
- [8] J.A.K. Suykens, J. Vandewalle, Least squares support vector machine classifiers, *Neural Processing Letters*, 9 (3), pages 293–300, 2002.
- [9] J.A.K. Suykens, T. Van Gestel, J. De Brabanter, B. De Moor, and J. Vandewalle, *Least squares support vector machines*, World Scientific Pub. Co, 2002.
- [10] A.J. Smola, P. Bartlett, B. Schölkopf, D. Schuurmans, *Advances in large margin classifiers* Cambridge, USA: MIT Press, 2000.
- [11] B. Schölkopf, A.J. Smola, *Learning with kernels*, MIT Press, USA, 2001.

- [12] G.C. Cawley, N. Talbot, and O. Chapelle, Estimating predictive variances with kernel ridge regression, In: *Machine Learning Challenges. Evaluating Predictive Uncertainty, Visual Object Classification, and Recognising Textual Entailment*. Ed. by J. Quiñonero-Candela, I. Dagan, B. Magnini, and F. d'Alchè-Buc. 3944 Lecture Notes in Computer Science, Springer Berlin Heidelberg, pages 273–286, 2006.
- [13] C. Currin, T. Mitchell, M.D. Morris, and D. Ylvisaker, *A bayesian approach to the design and analysis of computer experiments*, Technical Report ORNL 6498, 1988.
- [14] R. Jin, W. Chen, and A. Sudjianto, *On sequential sampling for global metamodeling in engineering design*, 2, 2002.
- [14] M. Johnson, L. Moore, and D. Ylvisaker, Minimax and maximin distance designs, *Journal of Statistical Planning and Inference*, 26, pages 131–148, 1990.

Cross-evaluation of two measures for the assessment of estimated state-space systems in operational modal analysis

Simon Marwitz¹

1: *Bauhaus-Universität Weimar, Institute for Structural Mechanics*

Abstract. The presented study is a contribution towards the assessment of uncertainties in operational modal analysis. It is well known, that the quality of the identified modal parameters depends on the quality of the measured vibration data and further sources of uncertainty. It is sought to enhance the process of an operational modal analysis by identifying relations between different sources of uncertainty. However, for such quality assessment a suitable target value or measure is required, which should be applicable to output-only measurements where there is no prior knowledge about the input or the modal characteristics of the structure under test. Several such measures exist in the literature. In this study the modal error contribution measure by Cara et al. is validated against the uncertainty bounds on the modal parameters by Reynders et al.. To study their behaviour and performance, simulated data was used, where noise levels, damping levels and closeness of modes were varied.

Implementing spectral element method to analyze in-plane vibration of curved beams

Nima Azizi¹, M. M. Saadatpour¹, M. Mahzoon²

1: Department of Civil Engineering, Isfahan University of Technology, Isfahan, Iran

2: School of Mechanical Engineering, College of Engineering, Shiraz University, Shiraz, Iran

Abstract. In this paper, based on the exact solution of homogeneous differential equations of in-plane motion of thin curved beams, spectral shape functions and dynamic stiffness matrix are evaluated. Based on the spectral shape functions, nodal load vector for arbitrary load is calculated and the whole procedure is formulated in frequency domain in order to be implemented in spectral element method. Some results which are compared to finite element method present the precision of the utilized method.

1 Introduction

Calculation of the dynamic response of curved beams is an important issue in different engineering problems. Many researchers have proposed different methods to analyze dynamic responses of curved beams subjected to various loading conditions or evaluate natural frequencies [1–7]. Therefore, in this paper based on spectral element method (SEM) in the frequency domain [8], first the shape functions are evaluated, then the dynamic stiffness matrix and nodal load vector for arbitrary loads are determined.

2 Theoretical formulation

According to Love's theory, differential equations of in-plane motion of a curved beam (see Fig. 1) with constant curvature and cross section in frequency domain are [6]

$$\begin{aligned} EI \left(\frac{1}{R} \frac{d^2 \hat{U}}{ds^2} - \frac{d^3 \hat{W}}{ds^3} \right) + EA \left(\frac{d\hat{W}}{ds} + R \frac{d^2 \hat{U}}{ds^2} \right) + \rho R A \omega^2 \hat{U} - i\eta R \omega \hat{U} &= 0, \\ EI \left(\frac{d^3 \hat{U}}{ds^3} - R \frac{d^4 \hat{W}}{ds^4} \right) - EA \left(\frac{\hat{W}}{R} + \frac{d\hat{U}}{ds} \right) + \rho R A \omega^2 \hat{W} - i\eta R \omega \hat{W} &= 0, \end{aligned} \tag{11}$$

where W and U are radial and tangential displacement, η , ρ , R , A , I and E are viscous damping per unit volume, density, radius of curvature, cross section, second moment of inertia and Young's modulus, respectively.

Let [5,8,9]

$$\hat{U} = A e^{-iks}, \quad \hat{W} = B e^{-iks}, \tag{12}$$

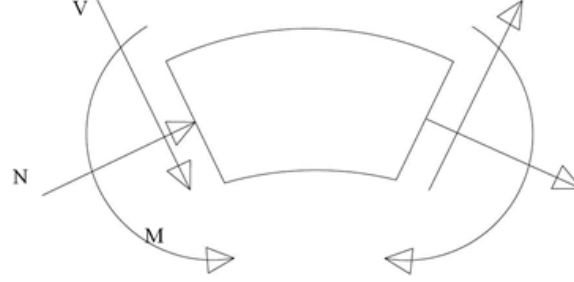

Figure 1: Curved beam element

where k is wave number. By putting Eqs. (12) into Eqs. (11), we get

$$\begin{pmatrix} k^2 \left(EA + \frac{EI}{R^2} \right) - \rho A \omega^2 + i\eta A \omega & ik \frac{EA + k^2 EI}{R} \\ -ik \frac{EA + k^2 EI}{R} & EI k^4 + \frac{EA}{R^2} - \rho A \omega^2 + i\eta A \omega \end{pmatrix} \begin{pmatrix} A \\ B \end{pmatrix} = \begin{pmatrix} 0 \\ 0 \end{pmatrix} \quad (13)$$

and

$$\alpha = \frac{A}{B} = - \frac{ik(EA + k^2 EI)}{R \left(k^2 \left(EA + \frac{EI}{R^2} \right) - \rho A \omega^2 + i\eta A \omega \right)}. \quad (14)$$

The nontrivial solution of Eq. (13) gives the characteristic equation of a curved beam as below,

$$A \left(E^2 I k^2 (-1 + k^2 R^2)^2 + iE (A + I k^2) R^2 (1 + k^2 R^2) \omega (\eta + i\rho\omega) + AR^4 \omega^2 (-i\eta + \rho\omega)^2 \right) = 0.$$

In order to evaluate the roots of characteristic equation some points related to multiple valued functions must be considered [8]. According to Eq. (14), Eq. (12) can be rewritten as below [5],

$$\begin{aligned} \hat{U} &= \alpha_1 B_1 e^{-ik_1 s} + \alpha_2 B_2 e^{-ik_2 s} + \alpha_3 B_3 e^{-ik_3 s} - \alpha_1 B_4 e^{-ik_1 s} - \alpha_2 B_5 e^{-ik_2 s} - \alpha_3 B_6 e^{-ik_3 s}, \\ \hat{W} &= B_1 e^{-ik_1 s} + B_2 e^{-ik_2 s} + B_3 e^{-ik_3 s} + B_4 e^{-ik_1 s} + B_5 e^{-ik_2 s} + B_6 e^{-ik_3 s}. \end{aligned}$$

Consequently, by evaluating the wave number according to the frequency, shape functions and dynamic stiffness matrix \mathbf{K}_e are obtained for a curved beam element with three degrees of freedom at each node (see Fig. 1).

$$\hat{\mathbf{K}}_e = \mathbf{H} \mathbf{G}^{-1},$$

where

$$\mathbf{H} = \begin{bmatrix}
 -AE \left(\frac{1}{R} - i\alpha_1 k_1 \right) & -AE \left(\frac{1}{R} - i\alpha_2 k_2 \right) & -AE \left(\frac{1}{R} - i\alpha_3 k_3 \right) \\
 \frac{EI k_1^2 (\alpha_1 + iRk_1)}{R} & \frac{EI k_2^2 (\alpha_2 + iRk_2)}{R} & \frac{EI k_3^2 (\alpha_3 + iRk_3)}{R} \\
 \frac{EI k_1 (\alpha_1 + iRk_1)}{R} & \frac{EI k_2 (\alpha_2 + iRk_2)}{R} & \frac{EI k_3 (\alpha_3 + iRk_3)}{R} \\
 \frac{AE e^{-ik_1 s} (1 - iR\alpha_1 k_1)}{R} & \frac{AE e^{-ik_2 s} (1 - iR\alpha_2 k_2)}{R} & \frac{AE e^{-ik_3 s} (1 - iR\alpha_3 k_3)}{R} \\
 \frac{iEI k_1^2 e^{-ik_1 s} (-i\alpha_1 + Rk_1)}{R} & \frac{iEI k_2^2 e^{-ik_2 s} (-i\alpha_2 + Rk_2)}{R} & \frac{iEI k_3^2 e^{-ik_3 s} (-i\alpha_3 + Rk_3)}{R} \\
 \frac{EI k_1 e^{-ik_1 s} (-i\alpha_1 + Rk_1)}{R} & \frac{EI k_2 e^{-ik_2 s} (-i\alpha_2 + Rk_2)}{R} & \frac{EI k_3 e^{-ik_3 s} (-i\alpha_3 + Rk_3)}{R} \\
 \\
 -AE \left(\frac{1}{R} - i\alpha_1 k_1 \right) & -AE \left(\frac{1}{R} - i\alpha_2 k_2 \right) & -AE \left(\frac{1}{R} - i\alpha_3 k_3 \right) \\
 -\frac{EI k_1^2 (\alpha_1 + iRk_1)}{R} & -\frac{EI k_2^2 (\alpha_2 + iRk_2)}{R} & -\frac{EI k_3^2 (\alpha_3 + iRk_3)}{R} \\
 \frac{EI k_1 (\alpha_1 + iRk_1)}{R} & \frac{EI k_2 (\alpha_2 + iRk_2)}{R} & \frac{EI k_3 (\alpha_3 + iRk_3)}{R} \\
 \frac{AE e^{ik_1 s} (1 - iR\alpha_1 k_1)}{R} & \frac{AE e^{ik_2 s} (1 - iR\alpha_2 k_2)}{R} & \frac{AE e^{ik_3 s} (1 - iR\alpha_3 k_3)}{R} \\
 \frac{iEI k_1^2 e^{-ik_1 s} (\alpha_1 + Rk_1)}{R} & \frac{iEI k_2^2 e^{-ik_2 s} (\alpha_2 + Rk_2)}{R} & \frac{iEI k_3^2 e^{-ik_3 s} (\alpha_3 + Rk_3)}{R} \\
 \frac{EI k_1 e^{-ik_1 s} (-i\alpha_1 + Rk_1)}{R} & \frac{EI k_2 e^{-ik_2 s} (-i\alpha_2 + Rk_2)}{R} & \frac{EI k_3 e^{-ik_3 s} (-i\alpha_3 + Rk_3)}{R}
 \end{bmatrix}$$

$$\mathbf{G} = \begin{bmatrix}
 \alpha_1 & \alpha_2 & \alpha_3 & -\alpha_1 & -\alpha_2 & -\alpha_3 \\
 1 & 1 & 1 & 1 & 1 & 1 \\
 \frac{\alpha_1}{R} + ik_1 & \frac{\alpha_2}{R} + ik_2 & \frac{\alpha_3}{R} + ik_3 & -\frac{\alpha_1}{R} - ik_1 & -\frac{\alpha_2}{R} - ik_2 & -\frac{\alpha_3}{R} - ik_3 \\
 \alpha_1 e^{-ik_1 s} & \alpha_2 e^{-ik_2 s} & \alpha_3 e^{-ik_3 s} & -\alpha_1 e^{ik_1 s} & -\alpha_2 e^{ik_2 s} & -\alpha_3 e^{ik_3 s} \\
 e^{-ik_1 s} & e^{-ik_2 s} & e^{-ik_3 s} & e^{ik_1 s} & e^{ik_2 s} & e^{ik_3 s} \\
 \frac{e^{-ik_1 s} (\alpha_1 + iRk_1)}{R} & \frac{e^{-ik_2 s} (\alpha_2 + iRk_2)}{R} & \frac{e^{-ik_3 s} (\alpha_3 + iRk_3)}{R} & -\frac{e^{ik_1 s} (\alpha_1 + iRk_1)}{R} & -\frac{e^{ik_2 s} (\alpha_2 + iRk_2)}{R} & -\frac{e^{ik_3 s} (\alpha_3 + iRk_3)}{R}
 \end{bmatrix}$$

For interpolating the deformation function, we have

$$\begin{bmatrix} \hat{U} \\ \hat{W} \end{bmatrix} = \mathbf{N} \cdot \mathbf{u} = \mathbf{N} \cdot \begin{bmatrix} u_1 \\ w_1 \\ \theta_1 \\ u_2 \\ w_2 \\ \theta_2 \end{bmatrix},$$

where \mathbf{N} and \mathbf{u} are matrix of shape functions and vector of nodal displacements respectively.

Since dynamic stiffness matrix and also shape functions are too large to store, they should be calculated for each frequency numerically.

Calculation of nodal load vectors due to any arbitrary dynamic load by using shape functions follows a standard procedure which is partly the same as straight beam elements and can be found in [10]. Therefore the procedure is explained briefly.

The nodal load vector for each element in frequency domain is derived according to principle of virtual work as below,

$$\hat{\mathbf{f}} = \int_0^s \hat{\mathbf{N}}^T \cdot \hat{\mathbf{l}}(\tilde{s}, \omega) d\tilde{s}, \quad (15)$$

where $\hat{\mathbf{f}}$ is nodal load vector in frequency domain, $\hat{\mathbf{l}}(\tilde{s}, \omega)$ is the external load vector in frequency domain, \tilde{s} is the local spatial coordinate of a curved beam element measured from the start point of each element and s is the length of an element. Considering the Fourier transform [8] we have,

$$\hat{\mathbf{l}}(\tilde{s}, \omega) = \begin{pmatrix} \hat{l}_u(\tilde{s}, \omega) \\ \hat{l}_w(\tilde{s}, \omega) \end{pmatrix} = \int_{-\infty}^{\infty} \begin{pmatrix} l_u(\tilde{s}, \omega) \\ l_w(\tilde{s}, \omega) \end{pmatrix} e^{i\omega t} dt, \quad (16)$$

where $\hat{l}_u(\tilde{s}, \omega)$ and $\hat{l}_w(\tilde{s}, \omega)$ are loads in tangential and radial directions. These loads in time domain can be divided to

$$\begin{pmatrix} l_u(\tilde{s}, t) \\ l_w(\tilde{s}, t) \end{pmatrix} = \begin{pmatrix} l_{us}(\tilde{s}) l_{ut}(t) \\ l_{ws}(\tilde{s}) l_{wt}(t) \end{pmatrix}. \quad (17)$$

$l_{us}(\tilde{s})$ and $l_{ut}(t)$ show the variation of the load with respect to the local spatial coordinate and time respectively in tangential direction. It is the same for radial direction. Regarding to Eqs. (15), (16) and (17) we get

$$\hat{\mathbf{f}} = \int_0^s \hat{\mathbf{N}}^T \cdot \hat{\mathbf{l}}(\tilde{s}, \omega) d\tilde{s} = \int_0^s \hat{\mathbf{N}}^T \cdot \begin{pmatrix} l_{us}(\tilde{s}) \int_{-\infty}^{\infty} l_{ut}(t) e^{i\omega t} dt \\ l_{ws}(\tilde{s}) \int_{-\infty}^{\infty} l_{wt}(t) e^{i\omega t} dt \end{pmatrix} d\tilde{s}. \quad (18)$$

It is difficult to calculate to integral parts of Eq. (18) analytically for arbitrary loads, so fast Fourier transformation [8] is utilized to calculate the integral with respect to time numerically and then also numerical procedure is used to calculate the integral with respect to . In order to evaluated nodal deformations Eq. (19) is solved and then by using inverse of fast Fourier transform, the response in time domain is calculated [8].

$$\hat{\mathbf{f}}_T = \hat{\mathbf{K}}_T \cdot \hat{\mathbf{u}}_T, \quad (19)$$

where $\hat{\mathbf{f}}_T$, $\hat{\mathbf{K}}_T$ and $\hat{\mathbf{u}}_T$ are nodal load vector of structure, dynamic stiffness matrix of structure and nodal displacement vector of structure respectively.

3 Numerical result

In this example a quarter of a circle is modeled by using circular beam depicted in Fig. 2 subjected to a load with $l_{ws}(s) = s$ and variation with respect to time as defined in Fig. 3. The radius of the beam is equal to 2 m , the cross section is IPE200 and material is DIN-ST37.

The radial deflection of the beam at point B and $\theta = \frac{\pi}{4}$ is depicted in Fig. 4 and Fig. 5 respectively. The finite element model is set up by using 10 standard straight beam elements.

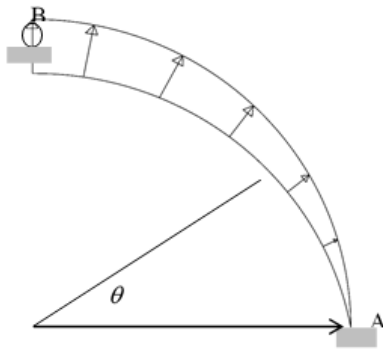

Figure 2: Curved beam element

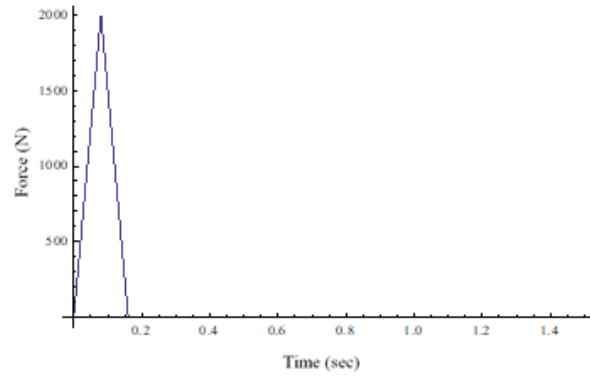

Figure 3: Loading function

4 Conclusion

In this paper, the spectral element method is used in order to study the response of in-plan vibration of curved beams under an arbitrary load. The formulation of numerical simulation of the method is presented and with comparing to the finite element results, it is shown that by using fewer elements in comparison with using standard straight beam elements, precise results can be achieved.

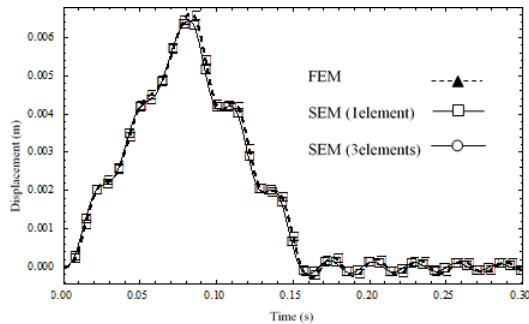

Figure 4: Radial deflection of curved beam at point B

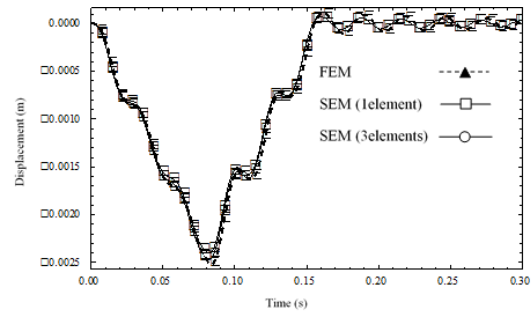

Figure 5: Radial deflection of curved beam at $\theta = \frac{\pi}{4}$

References

- [1] J.S.K. A. O. Lebeck, A finite element for the three-dimensional deformation of circular ring, *Int. J. Numer. Methods Eng.*, 21, 421–435, 1985.
- [2] J.F.W. B. K. Lee, Free vibration of arches with variable curvature, *J. Sound Vib.*, 136, 75–80, 1989.
- [3] S.D. D. Sengupta, Static and dynamic applications of a five noded horizontally curved beam element with shear deformation, *Int. J. Numer. Methods Eng.*, 40, 1801–1819, 1997.
- [4] N.I. Kim, D.K. Shin, A series solution for spatially coupled deflection analysis of thin-walled Timoshenko curved beam with and without elastic foundation, *J. Mech. Sci. Technol.*, 23, 475–488, 2009.
- [5] S.K. Lee, B.R. Mace, M.J. Brennan, Wave propagation, reflection and transmission in curved beams, *J. Sound Vib.*, 306, 636–656, 2007.
- [6] S.J. Walsh, R.G. White, Vibrational Power Transmission in Curved Beams, *J. Sound Vib.*, 233, 455–488, 2000.
- [7] Y.P. Tseng, C.S. Huang, M.S. Kao, In-plane vibration of laminated curved beams with variable curvature by dynamic stiffness analysis, *Compos. Struct.*, 50, 103–114, 2000.
- [8] J.F. Doyle, *Wave propagation in structures. Spectral analysis using fast discrete Fourier transforms*, Springer, 1997.
- [9] B. Kang, C.H. Riedel, C.A. Tan, Free vibration analysis of planar curved beams by wave propagation, *J. Sound Vib.*, 260, 19–44, 2003.
- [10] N. Azizi, M.M. Saadatpour, M. Mahzoon, Using spectral element method for analyzing continuous beams and bridges subjected to a moving load, *Appl. Math. Model.*, 36, 3580–3592, 2012.

Natural frequency analysis of cracked plates using Singular Finite Element Method

Parham Memarzadeh¹, Shiva Fesharakifard¹

1: *Civil Eng. Dept., Najafabad Branch, Islamic Azad University, Najafabad, Iran, p-memar@iaun.ac.ir*

2: *Civil Eng. Dept., Najafabad Branch, Islamic Azad University, Najafabad, Iran, fesharakifard@sci.iaun.ac.ir*

Abstract. A numerical model is presented for free vibration of a thin square isotropic plate containing a crack located at the center of the plate. The procedure used is singular finite element method through MATLAB software. In this regard, an eigenvalue analysis is performed to obtain the natural frequencies of the cracked plate by considering different boundary conditions. The first two modal shapes are formed for different ratios of crack length to plate width. The results are validated by comparing with those in other articles.

1 Introduction

Plate as a basic structural element is widely at risk of cracking, so analysis of cracked plates has been the subject of intensive investigations during recent decades. In fact, the presence of a crack in a plate causes changes in stiffness of the plate and affecting its static and dynamic characteristics. One of these characteristics is natural frequency that is analyzed in this study. Natural frequency of plates has already been analyzed by various methods, such as decomposition method [1], Ritz method [2] or generalized Rayleigh-Ritz method [3], Galerkin's method [4], finite element method [5-10] or generalized differential quadrature finite element method [11], extended finite element method [12], and also extended cell-based smoothed discrete shear gap method [13].

As known in theory of fracture mechanics, the stresses at the crack tips reach to infinity so that a phenomenon known as singularity occurs. This phenomenon is usually resulted in increasing of computing time of finite element analysis due to need to small mesh sizes around the crack tips. Thus, it is desirable to use a method to overcome this problem. This paper uses singular finite element method to frequency analysis of plates.

2 Singular finite elements

Singular elements are particular elements used around the crack tip to present the singularity of the crack. In fact, the exclusivity of them is their compatibility with singularity behavior. Owing to the fact that out-of-plane analysis of a cracked plate is affected by the in-plane stress distribution, to get more accurate results, an in-plane analysis should be first done. The singular element used for in-plane analysis has five nodes with two degrees of freedom at each node (u, v) shown in Fig. 1. More details of this element can be found in ref. [14].

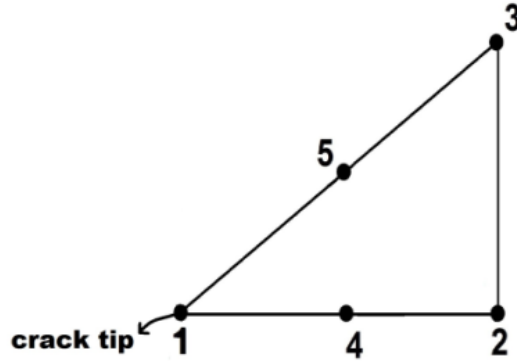

Figure 1: In-plane five-node singular triangular element [14]

The out-of-plane singular element used here has three nodes with three degrees of freedom at each node; including a transverse displacement and two rotations. The geometric of this element is contemporary shown in a Cartesian and polar coordinate system in Fig. 2. The transverse displacement, w , can be expressed in polar system as follow [15]:

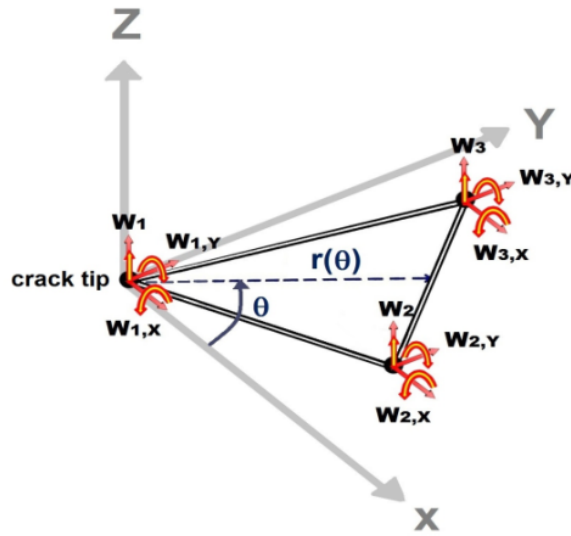

Figure 2: Out-of-plane three-node Singular triangular element [15]

$$w(r, \theta) = \alpha_1 + \alpha_2 r \cos \theta + \alpha_3 r \sin \theta + \alpha_4 r^{\frac{1}{2}} \cos \frac{\theta}{2} + \alpha_5 r^{\frac{1}{2}} \sin \frac{\theta}{2} + \alpha_6 r^{\frac{1}{2}} \left[\cos^3 \frac{\theta}{2} + \sin^3 \frac{\theta}{2} \right] + \alpha_7 r^2 \cos \theta \sin \theta + \alpha_8 r^2 \cos^2 \theta + \alpha_9 r^2 \sin^2 \theta$$

and in the matrix form displays as below:

$$w = [\varphi] \cdot [\alpha].$$

The relation between parameters α and nodal degrees of freedom is expressed as:

$$[W] = [C] \cdot [\alpha],$$

where $[C]$ is the corresponding transformation matrix. The well-known form of transverse displacement in finite element method is as:

$$w = [N] \cdot [W],$$

where $[N]$ are the element shape functions can be derived based on interpolation functions as following:

$$[N] = [\varphi] \cdot [C]^{-1}.$$

3 Finite element formulations

Free vibration of plates can be modeled mathematically by algebraic equations based on Energy theory as following:

$$\Pi = U - T,$$

where U is the total potential energy derived by:

$$U = U_b + U_g$$

U_b is the strain energy due to bending and U_g is the effect of in-plane forces on the transverse deflection.

$$U_b = \int \frac{Et^3}{12(1-\nu^2)} [w_{,xx}^2 + 2w_{,xx}w_{,yy} + w_{,yy}^2 + 2(1-\nu)w_{,xy}^2] dA$$

$$U_g = \int [N_{xx}w_{,x}^2 + 2N_{XY}w_{,X}w_{,Y} + N_{yy}w_{,y}^2] dA$$

and T is the kinetic energy obtained by:

$$T = \frac{\rho t \omega^2}{2} \int w^2 dA.$$

In above equations w is the transverse displacement and comma indicates partial differentiation with respect to the next subscribed variable, ω is the natural frequency, t is the plate thickness, ρ is the density of the plate material, E is the Young's modulus and ν is the Poisson's ratio. N_{xx} , N_{yy} and N_{XY} are in-plane stress resultants.

Based on principle of minimum total energy ($\delta\Pi = 0$), the eigen-equations of free vibration of the plate are obtained as below:

$$[(K_S + K_G) - \lambda M] [W] = 0.$$

Then, the dimensionless natural frequency λ is expressed as:

$$\lambda = \omega L^2 \sqrt{\frac{\rho t}{D}}$$

where L is the plate width.

4 Model descriptions

The MATLAB software is utilized for the modeling and vibration analysis of the considered cracked plate in this study. The geometric of the cracked plate is shown in Fig. 3.

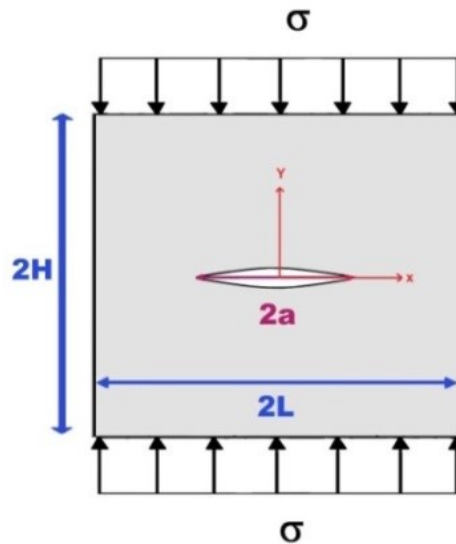

Figure 3: Specimen geometry

Two sides of the plate parallel to the crack line have in-plane restrictions subjected to uniform pressure. So two in-plane and out of plane models are coded for it. In both models, the crack was presumed to be through thickness since thin plate is used and having no friction else and no propagation was allowed. Three types of boundary conditions are considered for it, once has four simply supported sides (SSSS), other has two simply supports in its opposite sides and two clamped supports in its other sides (CSCS) and the last has four clamped sides (CCCC). The considered geometric parameters are: plate height and width $2H = 2L = 1.2m$, plate's thickness $t = 0.01m$, and relative crack's length $\frac{a}{L} = 0.0, 0.2, 0.4, 0.6, 0.8$.

The plate material is supposed to be linear elastic and isotropic with Young's modulus as: $E = 204GN/m^2$, Poisson's ratio $\nu = 0.3$ and density $\rho = 7860kg/m^3$.

In both in-plane and out of plane models, two kinds of singular and regular elements are used in this way, 8 singular triangular elements are located around each crack tip and a number of regular quadrature elements depend on the mesh sizes are used in other parts of plate. Regular elements have four nodes and the singular elements as previously explained have five nodes through in-plane and three nodes through out of plane models. Different mesh sizes are also used to get the sufficient convergence. The assembling samples of two models elements are shown in Figs. 4-5.

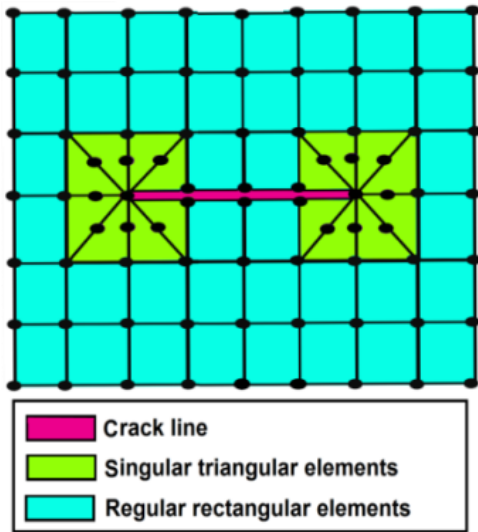

Figure 4: Assembling sample of in-plane model elements

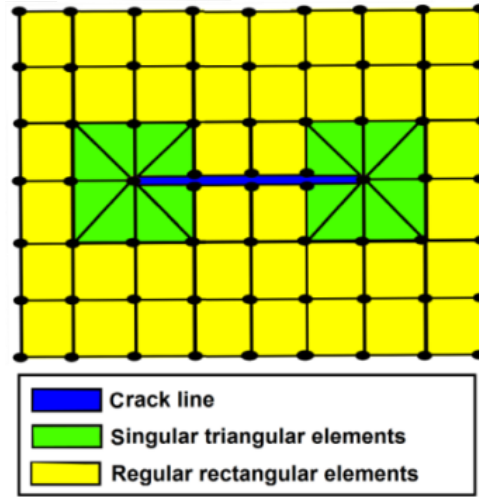
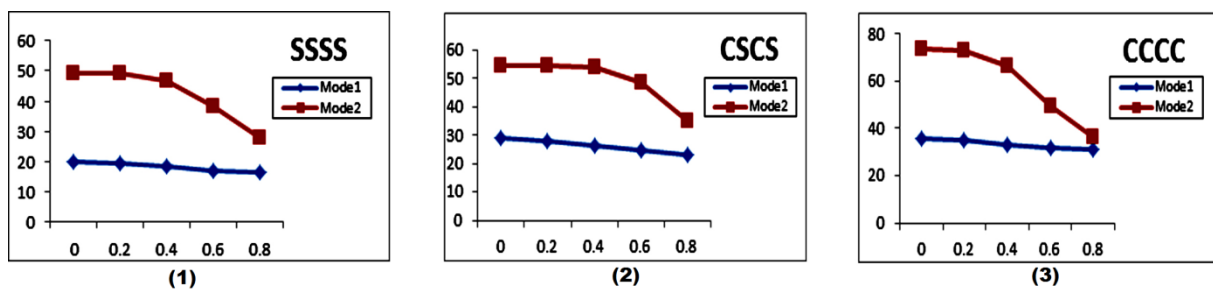

Figure 5: Assembling sample of out of plane model elements

5 Numerical results

In this section, natural frequencies are obtained for a square plate (aspect ratio=1). The results are comparing with other researchers studies just found for simply supported plate, [1, 16, 12, 13]. Table 1 shows the two lowest modes of non-dimensional frequency parameter λ compared to those in other articles. The results of the current analysis show good agreement.

It is important to observe how the frequency parameter changes with different crack lengths and types of supports. Consequently, diagrams 1, 2, 3 indicate the values of the first two non-dimensional frequency parameter λ versus different relative crack lengths $\frac{a}{L}$ for three types of supports.



Diagrams 1, 2, 3: changes of two first modes of non-dimensional frequency parameter λ versus different relative crack lengths for three types of supports

The mode shapes of obtained frequencies are also plotted in Fig. 6.

Aspect ratio=1				
Supports	Crack ration	Articles	Mode 1	Mode 2
SSSS	0.0	Liew et al. [1]	19.740	49.350
		Bachene et al.[12]	19.739	49.348
		T. Nguyen-Thoi et al. [13]	19.730	49.404
		Present study	19.730	49.323
	0.2	Liew et al. [1]	19.380	49.160
		Bachene et al.[12]	19.305	49.181
		Huang et al.[16]	19.330	49.190
		Present study	19.266	49.169
	0.4	Liew et al. [1]	18.440	46.440
		Bachene et al.[12]	18.278	46.635
		Huang et al.[16]	18.290	46.650
		Present study	18.261	46.709
	0.6	Liew et al. [1]	17.330	37.750
		Bachene et al.[12]	17.180	37.987
		Huang et al.[16]	17.190	37.990
		Present study	17.183	38.168
	0.8	Liew et al. [1]	16.470	27.430
		Bachene et al.[12]	16.406	27.753
		Huang et al.[16]	16.410	27.770
		Present study	16.416	27.917
CSCS	0.0	Present study	28.937	54.699
	0.2	Present study	28.087	54.609
	0.4	Present study	26.284	54.057
	0.6	Present study	24.469	48.302
	0.8	Present study	23.247	34.963
CCCC	0.0	Present study	35.962	73.331
	0.2	Present study	34.989	72.929
	0.4	Present study	33.168	66.430
	0.6	Present study	31.717	49.331
	0.8	Present study	31.145	36.226

Table 1: The first two modes of non-dimensional frequency parameter λ for different relative crack lengths $\frac{a}{L} = 0.0, 0.2, 0.4, 0.6, 0.8$ and three types of supports (simple, simple-clamped, clamped)

6 Conclusions

In the present paper, a numerical model based on singular finite element method (SFEM) has been developed for natural frequency of central cracked, square plates. In this procedure, the obtained eigen-equations have been implemented based on principle of minimum total energy $\delta\Pi = 0$, using MATLAB software and the effects of the crack length and different types of supports on the natural frequencies and the corresponding mode shapes

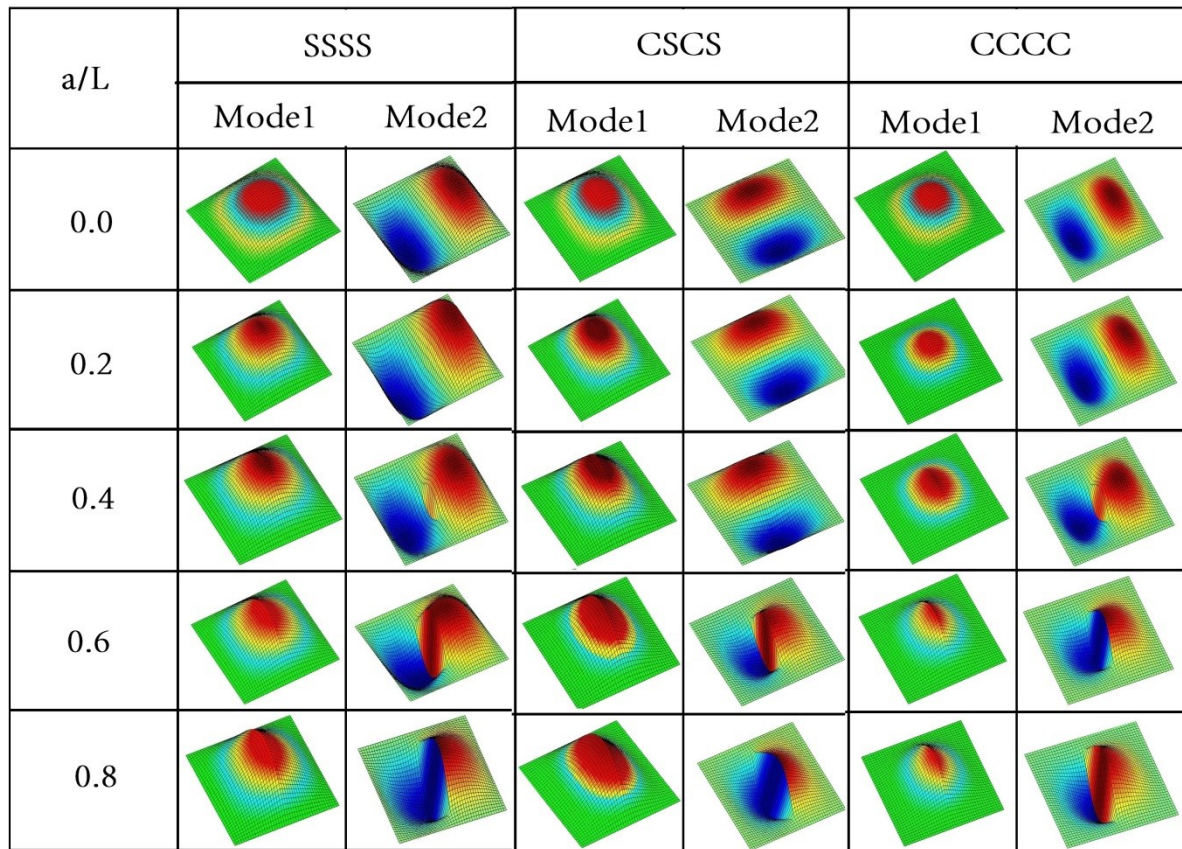

Figure 6: Mode shapes of non-dimensional frequency parameter λ for different relative crack lengths and three types of supports

have been investigated. On the basis of the achieved results the following conclusions can be stated:

1. The numerical simulations show that the frequency decreases as the crack length increases. This is due to the reduction in stiffness of the material structure.
2. The change in frequencies due to the presence of a crack is a function of the crack parameters and it also depends upon the mode shapes of the plate.
3. Existence of clamped supports causes higher increment of frequency in comparing with simple supports. The increase in stiffness is the cause for increase in frequency when the boundary condition is changed from SS to CS or CC.

The present results are in very good agreement with the numerical results reported in the literature so it can be concluded that the SFEM is an efficient method for the vibration analysis of cracked plates.

References

- [1] K.M. Liew, K.C. Hung, and M.K. Lim, A solution method for analysis of cracked plates under vibration, *Engineering Fracture Mechanics*, 48(3), 393–404, 1994.
- [2] C. S. Huang, A. W. Leissa, Vibration analysis of rectangular plates with side cracks via the Ritz method, *Journal of Sound and Vibration*, 323(3–5), 974–988, 2009.
- [3] V. Ramamurti, S. Neogy, Effect of crack on the natural frequency of cantilever plates a Rayleigh–Ritz solution, *Mech Struct Mach*, 26(2), 131–43, 1998.
- [4] P. V. Joshi, N. K. Jain, G. D. Ramtekkar, Effect of thermal environment on free vibration of cracked rectangular plate: An analytical approach, *Thin-Walled Structures*, 91, 38–49, 2015.
- [5] S. H. Yang, W. H. Chen, Free vibration analysis of patched cracked composite laminates using a multilayer hybrid-stress finite element method, *Engineering Fracture Mechanics*, 54(4), 557–568, 1996.
- [6] C. C. Ma, C. H. Huang, Experimental and numerical analysis of vibrating cracked plates at resonant frequencies, *Experimental Mechanics*, 41 (1), 8–18, 2001.
- [7] C. C. Ma, D. M. Hsieh, Full field experimental investigation sonresonant vibration of cracked rectangular cantilever plates, *AIAA Journal*, 39(12), 2419–2422, 2001.
- [8] N. A. H. saleh, Free vibration analysis of squared simply supported plates containing various crack configurations, *Al-Qadisiya Journal for Engineering Sciences*, Vol.2, 29-41, 2014.
- [9] A. Beigi et al, A numerical investigation into the crack effects on the natural frequencies of the plates, *International Journal of Maritime Technology*, 260, 19-44, 2003.
- [10] I. Senjanovic, N. Vladimir, D. S. Cho, A new finite element formulation for vibration analysis of thick plates, *International Journal of Naval Architecture and Ocean Engineering*, 7, 324-345, 2015.
- [11] N. Fantuzzi, F. Tornabene, E. Viola, Free vibrations of functionally graded cracked plates of arbitrary shape via GDQFEM, *6th ECCOMAS Conference on Smart Structures and Materials*, Italy, 2013.
- [12] M. Bachene, R. Tiberkak, and S. Rechak, Vibration analysis of cracked plates using the extended finite element method, *Archive of Applied Mechanics*, 79, 249–262, 2009.
- [13] T. Nguyen-Thoi et al, Free vibration analysis of cracked Mindlin plate using an extended cell-based smoothed discrete shear gap method (XCS-DSG3), *Theoretical and Applied Fracture Mechanics*, 72, 150–163, 2014.

- [14] M. Stern, Families of consistent conforming elements with singular derivative fields, *International Journal for Numerical Method in Engineering*, Vol. 14, 409-421, 1979.
- [15] D. Shaw, Y. H. Huang, Buckling behavior of a central cracked thin plate under tension, *Engineering Fracture Mechanics*, Vol. 35, No. 6, pp.1019-1027, 1990.
- [16] C.S. Huang, A.W. Leissa, C.W. Chan, Vibrations of rectangular plates with internal cracks or slits, *International Journal of Mechanical Sciences*, 53, 436–445, 2011.

Publications in the series of the Research Training Group 1462

Speakers of the group:

Prof. Dr. Ing. habil. Tom Schanz (2007-2008)

Prof. Dr. Ing. habil. Frank Werner (2008-2017)

The proposed Research Training Group will serve to build up a methodical basis which, for the first time, can assume the quality of prognosis models in engineering with a quantifiable form. Our approach will be limited to models of structural engineering at first. The state of scientific knowledge in structural engineering says that it is not possible to handle a common model with all the engineers involved in for reasons of complexity. To find out the model deviation, it is necessary to examine a complete model consisting of all the coupled partial models. This will be done by the use of own developed tools and methods based on the approaches of modern object and operational models.

Issue 1: Identifikation konstitutiver Parameter von weichen feinkörnigen Böden – Beitrag zum Konsolidationsverhalten von Ton

Martin M. Zimmerer

In Praxis und Wissenschaft ist bekannt, dass das zeitabhängige Setzungsverhalten von bindigem (tonigem) Baugrund infolge Konsolidation oft nur sehr ungenau prognostiziert werden kann. Ein Grund ist z.B. die große Abhängigkeit von den Entwässerungsbedingungen. Gegenstand dieser Arbeit ist die numerische Implementierung der nichtlinearen eindimensionalen Konsolidation, die bei diesen Fragestellungen eine sehr gute Näherung darstellt.

Die Möglichkeit, basierend auf Feldmessungen numerische Modelle und deren Materialmodellparameter zu kalibrieren, um Endsetzungen zu prognostizieren, wurde in dieser

Arbeit an der Sanierung industrieller Absetzbecken z.B. aus der Uranaufbereitung untersucht. Es wird exemplarisch gezeigt, wie es mithilfe von mathematischen und statistischen Analysen sowie Optimierungsmethoden in Verbindung mit einer nichtlinearen eindimensionalen Konsolidationstheorie möglich ist, Messprogramme für eine erfolgreiche Rückrechnung bzw. Prognose der Endsetzungen von industriellen Absetzbecken zu entwickeln, indem Messungen dort angeordnet werden, wo gewünschte Modellparameter besonders sensitiv gegenüber der Ergebnisgröße sind.

Issue 2: Evaluation methods for prediction quality of concrete models

Holger Keitel

The goal of this doctoral thesis is the development of methods for the evaluation of the prediction quality of creep models. The methods are distinguished into two scenarios: the evaluation with and without experimental data about the creep behavior of concrete. The model quality is quantified by the total uncertainty of the predicted creep compliance, composed of parameter and model uncertainty. The uncertainty of the creep prognosis without using measurement data is quantified by an uncertainty analysis taking into account the parameter correlation. In this case, the total model quality is determined from the time-dependent variation of the creep compliance. When experimental data of the creep behavior is considered the stochastic properties of the creep model parameters are found by means of Bayesian Updating. The evaluation is once more based on an uncertainty analysis using the identified model parameters. To provide an alternative for the evaluation method considering measurements, the Bayesian model selection is for the first time applied to creep models. This methodology is especially recommended for the evaluation of rheological creep models with hierarchical complexity. Examples show that the application of the developed methods enables efficient model quality evaluation. Furthermore, the choice of the most appropriate model reduces the uncertainty of the creep prognosis and as consequence the variation incorporated in the time-dependent analysis of global models of reinforced and prestressed concrete structures is reduced as well. Besides the evaluation of the creep partial model, an assessment method of coupled partial models based on graph theory and sensitivity analysis is developed. Therewith, the influence of classes of partial models on the global model response is quantified, interactions of partial models are detected, and a measure for the quality of the global model is derived.

Issue 3: Multicriterial evaluation method for the prognosis quality of complex engineering models

Markus Reuter

Within the scope of this dissertation, the evaluation of partial models and coupled partial models for the design and analysis of stave structure construction, under the usage of sustainable numerical methods, should be applied. For this purpose, significant output quantities subject to varying model qualities, diverse model couplings and disperse stochastic input parameters, as response surfaces, should be calculated. From the analysis of the response surface properties (e.g. consistency, coarseness etc.), conclusions regarding the sensitivity of the outcome quality subject to the input parameter should be derived.

Based on a reference model, for example, a larger hall-type structure, which is composed of specific joint constructions, foundation and roof structure, an attempt is made to implement diverse partial model couplings and obtain conclusions based on them, which can be evaluated using the presented methods. The essential elements of the tests are the diverse partial models for impact and material behaviour.

Based on the obtained findings it should be possible to give recommendations for a systematic analysis of the applied methods and models. This also includes other aspects of the designs.

Issue 4: Assessment of coupled models of bridges considering time-dependent vehicular loading

Ghada Karaki

Bridge vibration due to traffic loading has been a subject of extensive research in the last decades. The focus of such research has been to develop solution algorithms and investigate responses or behaviors of interest. However, proving the quality and reliability of the model output in structural engineering has become a topic of increasing importance. Therefore, this study is an attempt to extend concepts of uncertainty and sensitivity analyses to assess the dynamic response of a coupled model in bridge engineering considering time-dependent vehicular loading. A setting for the sensitivity analysis is proposed, which enables performing the sensitivity analysis considering random stochastic processes. The classical and proposed sensitivity settings are used to identify the relevant input parameters and models that have the most influence on the variance of the dynamic response.

The sensitivity analysis exercises the model itself and extracts results without the need for measurements or reference solutions; however, it does not offer a means of ranking the

coupled models studied. Therefore, concepts of total uncertainty are employed to rank the coupled models studied according to their fitness in describing the dynamic problem. The proposed procedures are applied in two examples to assess the output of coupled subsystems and coupled partial models in bridge engineering considering the passage of a heavy vehicle at various speeds.

Issue 5: Quality assessment of kinematical models by means of global and goal-oriented error estimation techniques

Susanne Nikulla

Methods for model quality assessment are aiming to find the most appropriate model with respect to accuracy and computational effort for a structural system under investigation. Model error estimation techniques can be applied for this purpose when kinematical models are investigated. They are counted among the class of white box models, which means that the model hierarchy and therewith the best model is known.

This thesis gives an overview of discretisation error estimators. Deduced from these, methods for model error estimation are presented. Their general goal is to make a prediction of the inaccuracies that are introduced using the simpler model without knowing the solution of a more complex model. This information can be used to steer an adaptive process. Techniques for linear and non-linear problems as well as global and goal-oriented errors are introduced. The estimation of the error in local quantities is realised by solving a dual problem, which serves as a weight for the primal error. So far, such techniques have mainly been applied in material modelling and for dimensional adaptivity. Within the scope of this thesis, available model error estimators are adapted for an application to kinematical models. Their applicability is tested regarding the question of whether a geometrical non-linear calculation is necessary or not.

The analysis is limited to non-linear estimators due to the structure of the underlying differential equations. These methods often involve simplification, e.g. linearisations. It is investigated to which extent such assumptions lead to meaningful results, when applied to kinematical models.

Issue 6: Data coupled civil engineering applications: modeling and quality assessment methods

Toni Fröbel

The planning process in civil engineering is highly complex and not manageable in its entirety. The state of the art decomposes complex tasks into smaller, manageable sub-tasks. Due to the close interrelatedness of the sub-tasks, it is essential to couple them. However, from a software engineering point of view, this is quite challenging to do because of the numerous incompatible software applications on the market.

This study is concerned with two main objectives: The first is the generic formulation of coupling strategies in order to support engineers in the implementation and selection of adequate coupling strategies. This has been achieved by the use of a coupling pattern language combined with a four-layered, metamodel architecture, whose applicability has been performed on a real coupling scenario. The second one is the quality assessment of coupled software. This has been developed based on the evaluated schema mapping. This approach has been described using mathematical expressions derived from the set theory and graph theory by taking the various mapping patterns into account. Moreover, the coupling quality has been evaluated within the formalization process by considering the uncertainties that arise during mapping and has resulted in global quality values, which can be used by the user to assess the exchange.

Issue 7: Procedurally generated models for isogeometric analysis

Peter Stein

In recent years, the definition of numerical models has become the bottleneck in the Finite Element Method. Characteristic features of the model generation are large manual efforts and a de-coupling of geometric and numerical model. In the highly probable case of design revisions, all steps of model preprocessing and mesh generation have to be repeated. This includes the idealization and approximation of a geometric model as well as the definition of boundary conditions and model parameters. Design variants leading to more resource-efficient structures might hence be disregarded due to limited budgets and constrained time frames. This thesis proposes a procedural approach for the generation of volumetric NURBS models. That is, a model is not described in terms of its data structures but as a sequence of modeling operations applied to a simple initial shape. In order to adapt this concept to NURBS geometries, only a compact set of commands is necessary, which, in turn, can be adapted from existing algorithms. A model can then

be treated in terms of interpretable model parameters, which drastically simplifies the setup of model variants. For the assessment thereof, Finite Element mesh quality metrics are regarded. The considered metrics are based on purely geometric criteria and allow to identify model degenerations commonly used to achieve certain geometric features. They can be used to decide upon model adaptations and provide a measure for their efficacy.

Issue 8: Quality assessment of dynamic soil-structure interaction models using energy measures

Mourad Nasser

In this research work, an energy approach is employed for assessing quality in dynamic soil-structure interaction (SSI) models, and energy measures are introduced and investigated as general indicators of structural response. Dynamic SSI models with various abstraction levels are then investigated according to different coupling scenarios for soil and structure models. The hypothesis of increasing model uncertainty with decreasing complexity is investigated and a mathematical framework is provided for the treatment of model uncertainty.

This framework is applied to a case study involving alternative models for incorporating dynamic SSI effects. In the evaluation process, energy measures are used within the framework of the adjustment factor approach in order to quantitatively assess the uncertainty associated with SSI models. Two primary types of uncertainty are considered, namely the uncertainty in the model framework and the uncertainty in the model input parameters. Investigations on model framework uncertainty show that the more complex three-dimensional FE model has the best quality of the models investigated, whereas the Wolf SSI model produces the lowest model uncertainty of the simpler models. The fixed-base model produces the highest estimated uncertainty and accordingly the worst quality of all models investigated.

These results confirm the hypothesis of increasing model uncertainty with decreasing complexity only when the assessment is based on the ratio of structural hysteretic energy to input energy as a response indicator.

Issue 9: Effiziente Methoden zur Analyse des Einflusses von Unsicherheiten in komplexen Ingenieurmodellen

Thomas Most

Im Ingenieurwesen ist die Berücksichtigung von Unsicherheiten beim Nachweis von Tragkonstruktionen unverzichtbar. Dabei kommen oftmals probabilistische Methoden zum Einsatz. Allerdings werden durch den Einzug numerischer Diskretisierungsverfahren, wie zum Beispiel der Finite Elemente Methode, viele Fragestellungen mit immer aufwendigeren Modellen untersucht. Die meisten probabilistischen Methoden sind aufgrund ihres hohen Aufwandes im Bezug auf die Anzahl von Modellauswertungen im Regelfall für solche komplexen Analysemodelle nur bedingt anwendbar. Weiterhin benötigen viele probabilistische Methoden ausreichend genaue Informationen über die stochastischen Eigenschaften der untersuchten unsicheren Modelleingangsgrößen, um nutzbare Ergebnisse zu liefern. Diese Informationen liegen speziell im Bauingenieurwesen aufgrund mangelnden Wissens oder aufwendiger Messverfahren oftmals nur eingeschränkt vor.

Im Rahmen dieser Arbeit wurden Methoden zur Variations-, Sensitivitäts- und Zuverlässigkeitsanalyse, welche dazu dienen, die Streuung von Ergebnisgrößen, deren Ursachen sowie Auftretenswahrscheinlichkeiten von Versagensszenarien zu analysieren, näher untersucht und weiterentwickelt. Dabei wurde einerseits auf eine effiziente Anwendbarkeit Wert gelegt, und andererseits die Aussagequalität infolge mangelnder Informationen bewertet.

Issue 10: Mehrphasensysteme in der Geotechnik – Experiment und Simulation

Frank Wuttke

Die Geotechnik innerhalb des Bauingenieurwesens umfasst eine Vielzahl von Arbeitsgebieten wie das Materialverhalten, die Boden-Bauwerk-Interaktion, den Spezialtiefbau, die Umweltgeotechnik oder das geotechnische Erdbebeningenieurwesen, um nur einige zu benennen.

Im Allgemeinen sind geotechnische Modellierungen in Experiment oder Simulation unter Berücksichtigung der Mehrdimensionalität, der Mehrphasigkeit als auch der porösen und teilweise granularen Struktur zu tätigen. Die besondere Komplexität eines mehrphasigen Materials in experimenteller Analyse und numerischer Modellierung bedingt einen Mangel an Prognosemethoden für diese Randbedingungen.

Die hier vorgestellten Neu- und Weiterentwicklungen sollen einen Beitrag zur Lösung von einigen Problemstellungen in der Geotechnik diesbezüglich leisten. Die Arbeit beinhaltet unterschiedliche Entwicklungen zur Verbesserung des Änderungsmonitoring der Materialstruktur, der Weiterentwicklung von Makromodellen in der Boden-Bauwerks-Interaktion als auch der Entwicklung von hybriden numerischen Modellen zur Ausbreitung von Wellenfeldern in großen geologischen Strukturen.

Issue 11: 12th International Probabilistic Workshop November 4th-5th 2014

Proceedings

The proceedings at hand are the result from the 12th International Probabilistic Workshop held at the Bauhaus-Universität Weimar, 2014. It comprises a collection of articles devoted to future oriented fields of stochastic theory, statistics and optimization both in applied sciences and theory.

Among the covered topics and techniques applied are: Risk analysis, robust topology optimization, the quantification of uncertainties, sensitivity analysis, reliability methods, model quality assessment, design of experiments and surrogate modeling. The applications comprise fields of structural analysis, material science, geosciences, natural hazard and electrical engineering.

The authors are both, well experienced specialists and young researchers, from more than 12 countries worldwide who share their deep interest in modern probability theory and stochastic simulation techniques.

Issue 12: Evaluation of the coupling between an analytical and a numerical solution for boundary value problems with singularities

Dmitrii Legatiuk

Often in practice one has to deal with problems containing different types of singularities (crack, gaps, etc.). To handle such problems by numerical methods one needs to perform some adaptations in the region near the singularity. The finite element method is the most popular numerical method among the others, which allows to construct an approximate solution for singular problems after a certain level of refinement.

An alternative to numerical methods are the function theoretic methods, which allow to construct an exact solution to a boundary value problem with a singularity. But due to the fact that these methods are restricted to some canonical domains, their real applications are rather limited.

The idea of this thesis is to propose a method which can combine the advantages of the FEM and the function theoretic methods in one procedure. This combination is realised by constructing an exact solution to a differential equation in the small region near a singularity and by coupling this analytical solution with the finite element solution in the remaining part of a domain.

This thesis shows a way how to construct a continuous coupling between two solutions. The continuity is ensured by a special interpolation operator, which is constructed on the interface between the two solutions. The unique solvability of the corresponding interpolation problem is proved in this thesis. First steps in the convergence analysis and the error estimation are performed and proved. Several numerical examples including a realistic example of the engineering practice are presented. This work indicates that such a method of coupling has a potential to become a useful tool in practical applications. The idea is that by working with the analytical solution near the singularity one can expect a better convergence rate in this region.

Issue 13: Evaluation of coupled partial models for the assessment of restraint effects in concrete structures

Bastian Jung

Numerical simulations are common for the design process of structures and the assessment of existing buildings. In the design process, several physical phenomena are represented by partial models. These models are coupled together to predict the behavior of the observed structure. Engineers have to decide which phenomena should be considered in the structural model. This process is often made by engineering judgement. In most cases, such models includes some amount of inaccuracy and incompleteness. Therefore, the integrative assessment method is established here to quantitatively evaluate the entire structural load-bearing behavior, which can significantly reduce the uncertainty in model predictions. The probability of occurrence of structural damages during lifetime can be clearly reduced.

Issue 14: Quality assessment methods for experimental models in structural engineering

Hem Bahadur Motra

Experimental and numerical models are required in order to reliably assess the safety and usability of both newly constructed and existing structures. The quality of both numerical and experimental models must be evaluated in order to reliably predict structural behaviour and design. Many statements about the quality of a simulation model can only be validated by including the appropriate experiments e.g. the quantification of the statistical uncertainties of model input parameters during the calibration of the confidence level estimator model, which is dependent heavily on the definition of the experiment and the quality of its implementation. Metrological aspects should therefore be used in order to guarantee the equivalence of results between different laboratories and evaluate the measurement or simulation result with its specifications. However, methodology for quantitatively assessing the implementation and results of experimental models is lacking. This work presents methods for assessing the quality of different materials used in structural engineering and monitoring models.

Issue 15: Goal-oriented adaptive modeling of 3d elastoplasticity problems

Seyed Shahram Ghorashi

In finite element simulation of engineering applications, accuracy is of great importance. By applying a mesh adaptivity procedure more accurate results with lower computational effort can be achieved. For this purpose error estimation methods are utilized as guidance for mesh adaptation. Conventional error estimations compute the error in energy norms which are not of interest in engineering applications. Therefore, goal-oriented error estimations have been developed in order to approximate the error with respect to a quantity of interest. In the present work an efficient adaptivity methodology for analysis of three-dimensional elastoplasticity problems based on goal-oriented error estimation is developed and its performance is investigated through several numerical investigations.

Issue 16: Assessment of numerical prediction models for aeroelastic instabilities of bridges

Tajammal Abbas

The phenomenon of aerodynamic instability caused by the wind is usually a major design criterion for long-span cable-supported bridges. If the wind speed exceeds the critical flutter speed of the bridge, this constitutes an Ultimate Limit State. The prediction of the flutter boundary, therefore, requires accurate and robust models. The complexity and uncertainty of models for such engineering problems demand strategies for model assessment. This study is an attempt to use the concepts of sensitivity and uncertainty analyses to assess the aeroelastic instability prediction models for long-span bridges. The state-of-the-art theory concerning the determination of the flutter stability limit is presented. Since flutter is a coupling of aerodynamic forcing with a structural dynamics problem, different types and classes of structural and aerodynamic models can be combined to study the interaction. Here, both numerical approaches and analytical models are utilised and coupled in different ways to assess the prediction quality of the coupled model.

MEETING BROCHURE

GRK 1462 International Workshop



Coupled Numerical and Experimental Models in Structural Engineering

26th - 28th April 2017

**Bauhaus-
Universität
Weimar**

**RUHR
UNIVERSITÄT
BOCHUM**

RUB

DFG

Deutsche
Forschungsgemeinschaft

**TU
WIEN**

MEETING BROCHURE

for the GRK International Workshop

Coupled Numerical and Experimental Models in Structural Engineering

26th - 28th April 2017
at Bauhaus-Universität Weimar

Participants & Partners

**Bauhaus-
Universität
Weimar**

RUHR
UNIVERSITÄT
BOCHUM

RUB

DFG Deutsche
Forschungsgemeinschaft

**TU
WIEN**

CONTACT INFORMATION

Graduiertenkolleg 1462

Dr.-Ing. Lars Abrahamczyk
Marienstraße 7A, Zimmer 309
99423 Weimar

Tel.: +49 (0) 36 43/ 58 4103
Fax: +49 (0) 36 43/ 58 4101
E-Mail: ceo.grk1462@uni-weimar.de

CONTENT

general information

Scope & Conference topic	4
The Event Location	5
Further Information	6
Site Plan	7

program overview

Wednesday	8
Thursday	9
Friday	10

list of participants	12
----------------------------	----

organization & comittee	14
-------------------------------	----

general information

SCOPE & CONFERENCE TOPICS

Solution of any engineering problem is based on a model. The solution quality strongly depends on characteristics of the used model. Moreover, modern problems of engineering typically require not only single models, but rather a combination of different partial models. Thus the coupling quality influences significantly the quality of the result. Therefore, the research area of the GRK 1462 is estimation of quality of the coupled global model depending on partial models and input parameters. This research covers such topics as stochastic, adaptive, inverse, and meta modelling.

The workshop is covering the following topics of particular interest:

- Model abstraction in Theory and Practice
- Verification & Validation of Engineering Models
- Coupling of Models
- Design of Experiments

THE EVENT LOCATION

In style of an Italian nobility house, the Villa Haar is one of Weimars most exclusive conference buildings.

A unique mixture of nature and traditional culture offers a reasonable setting for any type of coaching, training, and else. Inside one can find beautiful daylight due to the nearby Goethepark, which is visible from inside the Villa as well.





The Villa Haar building at dusk

(copyright: Ralph Kallenbach)

CULTURAL EVENTS

Besides the lectures a cultural programme, consisting of a welcome reception, guided sightseeing tour and conference dinner will be provided.

<i>Welcome Reception:</i> Kasseturm		19:00
<i>Sightseeing:</i> meeting in front of the conference venue		18.00
<i>Dinner:</i> at conference venue		19:30

Weimar is well known because of its large cultural heritage. The city was a focal point of the German Enlightenment and home of the leading characters of the literary genre of Weimar Classicism, the writers Johann Wolfgang von Goethe and Friedrich Schiller. Different cultural activities will be organized about the history of Weimar and the Bauhaus-Universität Weimar. Highlights will be:

- Roman House
- Goethe's Gardenhouse
- Place of Democracy

ARRIVAL

The conference will take place at *Villa Haar* in the center of the Goethe Park. To get there, a 15 to 20 minutes walk from the city center / hotel through the park is estimated.

Parking space is available right next to the building as well as in the direct surrounding. The adress of the event location is:

Dichterweg 2A
99423 Weimar
(For further details: see site plan on the next page)

SITE PLAN

A map of Weimar showing the main points of interest for the workshop and its activities. Due to the manageable size of the city, every location is conveniently accessible on foot.

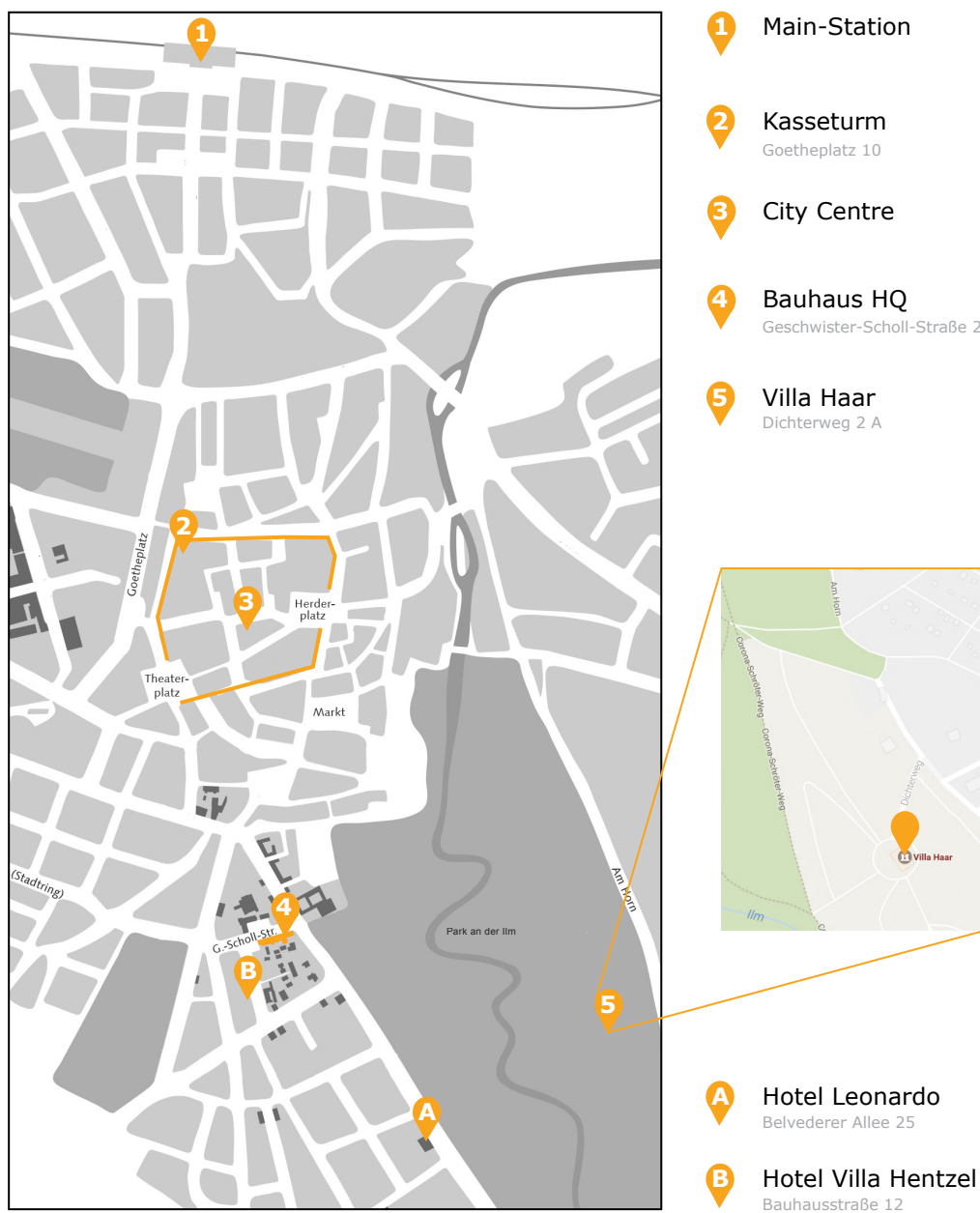

program overview

Wednesday
26th April 2017

Models in Society and Technics

Time	Title	Speaker
12:30	Registration	
13:00 - 13:30	Opening	F. Werner (BUW) W. Speitkamp (President) Ch. Karcher (TU Ilmenau)
13:30 - 14:30	Climate Models – Challenges, Techniques & Quality <i>coffee & communication break</i>	G. Feulner (PIK)
Session I	Models in Society and Technics	
15:00 - 17:30	Models from Theory into Practice	F. Werner (BUW)
	Interaction Modeling in Mechanized Tunneling	G. Meschke (RUB)
	Structural optimization under stochastic uncertainty	Ch. Bucher (TU Vienna)
	Designing Uncertainties in Robust Design	T. Most (Dynardo GmbH)

Verification & Validation and Design of Experiments

Thursday
27th April 2017

Time	Title	Speaker
Session II		
Validation & Verification		
9:00 – 10:10	Efficient Reliability Analysis of Systems in Uncertain Environments	M. Beer (Uni Hannover)
	Structural steel design by experiments and FE analysis	L. Dunai (BME, Hungary)
<i>coffee & communication break</i>		
10:40 – 12:40	Recent advances in thunderstorm downbursts: Field measurements, weather survey, laboratory tests, numerical simulations and loading of structures	G. Solari (Uni of Genova)
	Evaluation of spatial soil variability in the Pearl River Estuary using CPTU data	E. Bombasaro (Italy)
	Evaluation of Steel Buildings by means of non-destructive Testing Methods	Ch. Fox (TU Kaiserslautern)
	Higher order Riesz-transform in the context of Multi-Resolution Orientation Estimation	M. Reinhardt (TU Freiberg)
Session III		
Design of Experiments & Monitoring Systems		
13:30 – 15:20	Optimal Experimental Design for parameter identification in a geotechnical application	R. Hölter (RUB)
	GRK 1462 - Reference Project „Poles“: Monitoring System, Lab Experiments, and long-term measurement	M. Kraus (BUW)
	Measurement uncertainty and prediction quality	S. Rau (BUW)
<i>coffee & communication break</i>		
15:50 – 18:00	GRK 1462 - Reference object: „Radio Tower“: Long Time Monitoring to Assess Different Aspects of Uncertainty	V. Zabel (BUW)
	Embedding models into wireless sensor nodes for structural health monitoring	M. Dragos (BUW)
	Model-based force identification and response estimation	G. Lombaert (KU Leuven)
	Rapid seismic vulnerability assessment of buildings for civil protection	Y. Petryna (TU Berlin)

Cultural Event: Sightseeing & Dinner

Friday

28th April 2017

Coupling of Models

Time	Title	Speaker
Session IV 9:00 – 10:30	Multiphase & Multiscale Modelling From pore-scale physics to multiphase models for engineering problems Early-age elastic and viscoelastic properties of polymer-modified cement pastes derived from experimental and semi-analytical multiscale approaches Experimental and Numerical Analyses of Welded Connections Multiscale Models: From Nano-Scale to Large-Scale Structures coffee & communication break	H. Steeb (Uni Stuttgart) L. Göbel (BUW) I. Wudtke (BUW) A. Tanhadoust (Isfahan University)
Session V 11:00 – 13:00	Problems of Coupling Conceptual modelling methodology for assessment of coupling of models Aerodynamic modelling via Categorical Approach Uncertainty-based Evaluation and Coupling of Mathematical and Physical Models GRK 1567 „Lorentz Force Velocimetry and Lorentz Force Eddy Current Testing“	D. Legatiuk (BUW) I. Kavrakov (BUW) H. B. Motra (CAU Kiel) J. Schumacher (TU Ilmenau)
Session VI 14:00 – 16:00	Inverse and Meta Modelling Inverse and Ill-Posed Problems in Coupled Systems Surrogate Models for Real-Time Predictions in Mechanized Tunneling Investigation of a global adaptive sampling method based on Least-square support vector regression Cross-evaluation of two measures for the assessment of estimated state-space systems in operational modal analysis	T. Lahmer (BUW) St. Freitag (RUB) M. Steiner (BUW) S. Marwitz (BUW)

about GRK 1462

EVALUATION OF COUPLED NUMERICAL AND EXPERIMENTAL MODELS

The *Graduiertenkolleg 1462* is supported by the German Research Foundation (*Deutsche Forschungsgemeinschaft*) since 2008.

At the GRK for the first time methodical basics are supposed to be created, with those help the quality of forecast models in civil engineering - presently focused on constructive engineering - can be evaluated in a quantitative way. The current stand of science says, that a collective model of all involved engineers is not manageable, due to its complexity. The detection of a difference to that model needs a contemplation of the partial models, coupled to the overall model.

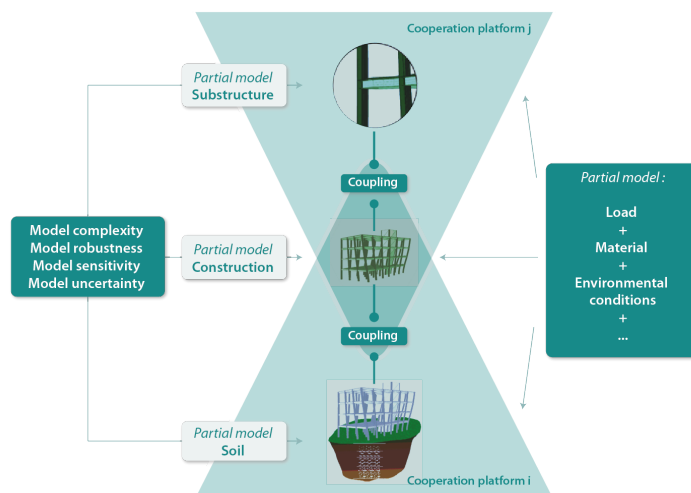

list of participants

Abrahamczyk, Lars, Bauhaus-Universität Weimar
Alalade, Muyiwa, Bauhaus-Universität Weimar
Al Hanoun, Hisham, Bauhaus-Universität Weimar
Alkam, Feras, Bauhaus-Universität Weimar
Beer, Michael, Leibniz Universität Hannover
Bock, Sebastian, Bauhaus-Universität Weimar
Bombasaro, Emanuel, Bedeschi Handling S.P.A.
Bucher, Christian, TU Wien
Doktor, Markus, TU Kaiserslautern
Dragos, Kosmas, Bauhaus-Universität Weimar
Dunai, László, Budapest University of Technology and Economics
Feulner, Georg, Potsdam-Institut für Klimafolgenforschung
Freitag, Steffen, Ruhr Universität Bochum
Fox, Christian, TU Kaiserslautern
Göbel, Luise, Bauhaus-Universität Weimar
Gürlebeck, Klaus, Bauhaus-Universität Weimar
Hausbrandt, Susanne, SGHG Ingenieurgruppe Bautechnik
Häußler-Combe, Ulrich, TU Dresden
Hölter, Raoul, Ruhr Universität Bochum
Hosseini, H.R., Isfahan University of Technology
Jafarian, Navid, Isfahan University of Technology
Jaouadi, Zouhour, Bauhaus-University Weimar
Karcher, Christian, TU Ilemenau
Kavrakov, Igor, Bauhaus-Universität Weimar
Keitel, Holger, SGHG Ingenieurgruppe Bautechnik
Könke, Carsten, Bauhaus-Universität Weimar
Kraus, Matthias, Bauhaus-Universität Weimar
Lahmer, Tom, Bauhaus-Universität Weimar
Legatiuk, Dmitrii, Bauhaus-Universität Weimar

Lombaert, Geert, KU Leuven
Marwitz, Simon, Bauhaus-University Weimar
Meschke, Günther, Ruhr Universität Bochum
Most, Thomas, Dynardo GmbH
Motra, Hem, CAU Kiel
Mucha, Felix, Bauhaus-Universität Weimar
Nöthlich, Anne-Marie, Bauhaus-Universität Weimar
Petryna, Yuri, TU Berlin
Rau, Sebastian, Bauhaus-Universität Weimar
Reichert, Ina, Bauhaus-Universität Weimar
Reinhardt, Martin, TU Freiberg
Sahlmen, Jörg, Ruhr Universität Bochum
Saubke, Vanessa, Ruhr Universität Bochum
Schmidt, Albrecht, Bauhaus-Universität Weimar
Schumacher, Jörg, TU Ilmenau
Schwarz, Jochen, Bauhaus-Universität Weimar
Smarsly, Kay, Bauhaus-Universität Weimar
Solari, Giovanni, University of Genova
Speitkamp, Winfried, Bauhaus-Universität Weimar
Steeb, Holger, Universität Stuttgart
Steiner, Maria, Bauhaus-Universität Weimar
Tahir, Arslan, Bundesanstalt für Wasserbau
Tan, Fengjie, Bauhaus-Universität Weimar
Tanhadoust, Amin, Isfahan University of Technology
Tuan-Nguyen, Long, Bauhaus-Universität Weimar
Werner, Frank, Bauhaus-Universität Weimar
Wolf, Frank, Ingenieurbüro Dr. Wolf
Wudtke, Idna, Bauhaus-Universität Weimar
Zabel, Volkmar, Bauhaus-Universität Weimar

organization & comittee

SCIENTIFIC AND TECHNICAL ORGANIZATION

Prof. F. Werner, Weimar, Germany
Prof. G. Morgenthal, Weimar, Germany
Prof. T. Lahmer, Weimar, Germany
Prof. M. Kraus, Weimar, Germany
Prof. K. Smarsly, Weimar, Germany
Dr.-Ing. L. Abrahamczyk, Weimar, Germany
Dr. rer. nat. D. Legatiuk, Weimar, Germany

SCIENTIFIC COMITTEE

Prof. C. Könke, Weimar, Germany
Prof. K. Gürlebeck, Weimar, Germany
Prof. A. Osburg, Weimar, Germany
Prof. K. Beucke, Weimar, Germany
Prof. G. Meschke, Bochum, Germany
Prof. T. Schanz, Bochum, Germany
Prof. em. D. Hartmann, Bochum, Germany
Prof. Ch. Bucher, Vienna, Austria
Prof. L. Dunai, Budapest, Hungary
Prof. M. Beer, Hannover, Germany
Prof. G. Lombaert, Leuven, Belgium
Dr.-Ing. J. Hildebrand, Ilmenau, Germany
Dr.-Ing. J. Schwarz, Weimar, Germany

CORPORATE DESIGN & GENERAL APPEARANCE

Dominic Dives, B.F.A., Weimar, Germany

Dominic.Dives@uni-weimar.de

**Bauhaus-
Universität
Weimar**

**RUHR
UNIVERSITÄT
BOCHUM**

RUB

DFG

Deutsche
Forschungsgemeinschaft

**TU
WIEN**